

SIAT

■ M. J. MAILLIS GROUP

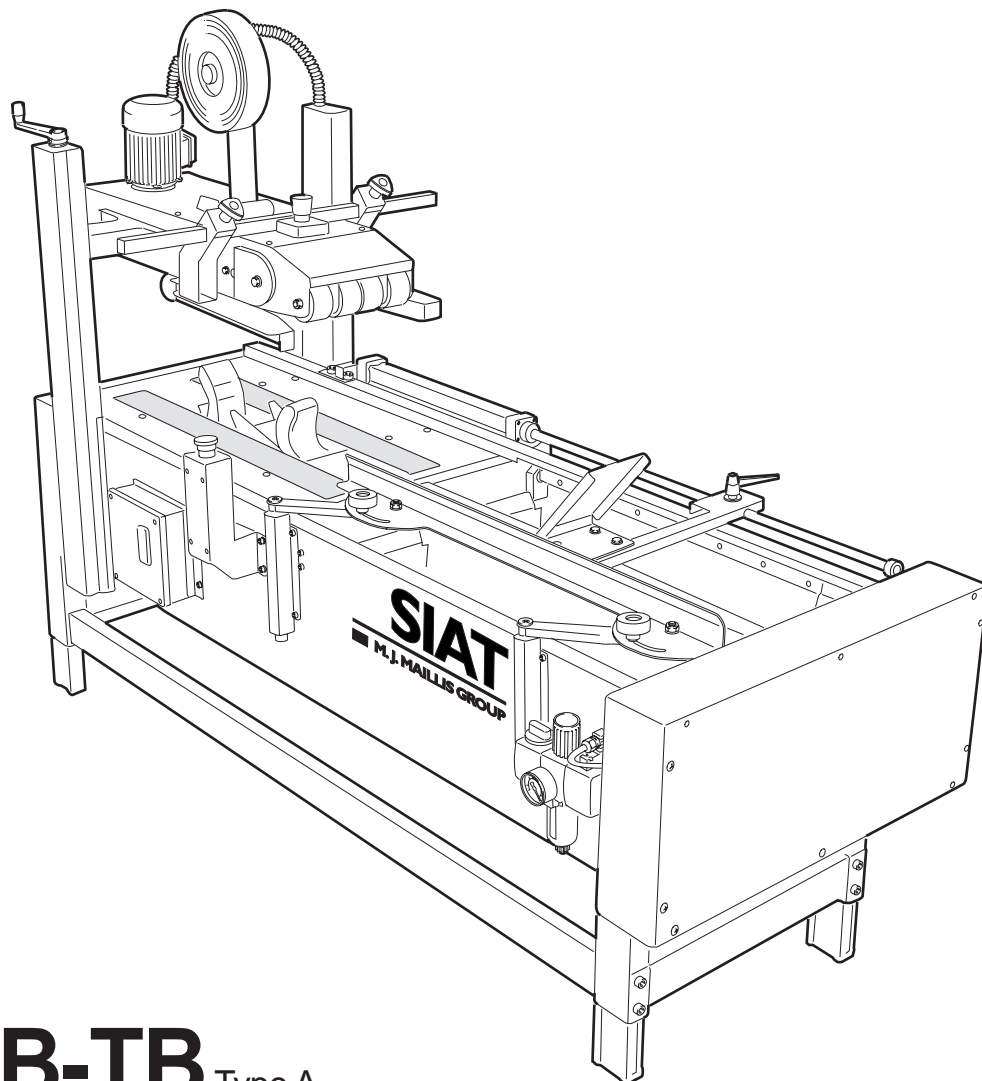

PS50B-TB Type A

STAZIONE DI CONFEZIONAMENTO E NASTRATURA CARTONI SEMIAUTOMATICA

SEMI-AUTOMATIC BOX FILLING/SEALING STATION

STATION DE CONFECTIONNEMENT ET ENRUBANNAGE SEMI-AUTOMATIQUE DES CARTONS

HALBAUTOMATISCHE STELLE ZUR KARTONSFUELLUNG/VERSCHLUSS
ESTACION DE CONFECCIONAMENTO Y SELLADO SEMI-AUTOMATICA DE LAS CAJAS

MANUALE DI ISTRUZIONI E PARTI DI RICAMBIO
INSTRUCTIONS MANUAL AND SPARE PARTS LIST
MANUEL D'INSTRUCTIONS ET PIECES DETACHEES
BEDIENUNGSANLEITUNG UND ERSTAZTEILLISTE
MANUAL DE INSTRUCCIONES Y RECAMBIOS



Instruction manual for the use, maintenance, safety, shipment, storage, unpacking, set-up, repairing, spare parts and disposal concerning the semi-automatic box filling sealing station PS50B, PS50TB Type A.

This publication is property of SIAT S.P.A.
Via Puecher, 22 - 22078 TURATE (CO) - ITALY
Tel. 02-964951 - Fax. 02-9689727

Edition: Nov 2008

The reproduction of this manual is strictly forbidden.
All rights reserved ©Siat S.p.A. 2008

The manufacturer reserves the right to modify the machines at any time without notice, therefore the following machines could differ from the present one and the manual to be integrated only for the changes related to the safety.

Publication n° SMB00062K
Release 0

This publication is composed of n. 39 pages

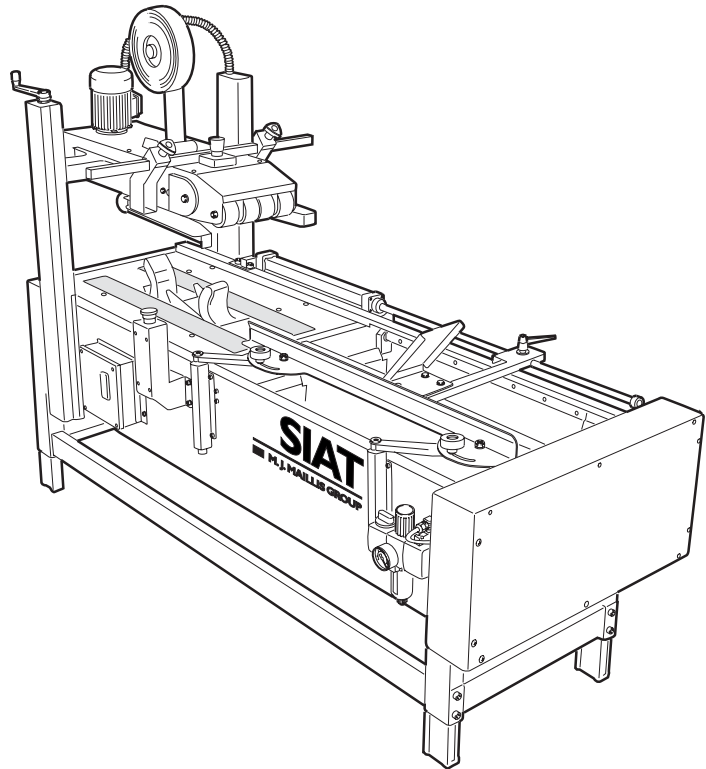

PS50B-TB Type A

SEMI-AUTOMATIC BOX FILLING/SEALING STATION PS50B (with bottom driving belts), PS50TB (with top and bottom driving belts)

- Maximum box size **l.** 600 mm, **h.** 500 mm, **w.** 500 mm
- Adhesive tape 50 mm
- Belt speed 22 m/minuto
- Production 480÷600 boxes/hour

Section 1-INTRODUCTION

Manufacturing specifications1.1
 How to read and use the instruction manual.....1.2

Section 2-GENERAL INFORMATION

Machine serial number and name of the manufacturer2.1
 After-sale service2.2
 Warranty2.3

Sezione 3-SAFETY INFORMATION

General safety information3.1
 Operator's qualification3.2
 Instructions for a safe use of the machine3.3
 State of the machine3.4
 Number of the operators3.5
 Operator's skill level3.6
 Residual hazards3.7
 Personal safety measures3.8
 Incorrect and not allowed actions3.9
 Warnings, labels, plates and drawing on the machine3.10

Section 4-PRELIMINARY INFORMATION

General description of the machine4.1
 Technical specifications4.2
 Tape dimensions4.3
 Purpose dimension4.4
 Box size range4.5
 Main components.....4.6
 Operative flow4.7
 Overall dimensions4.8
 Machine noise measurement.....4.9

Section 5-SHIPPING-HANDLING-STORAGE

Shipping and handling of the packed machine5.1
 Shipping and handling of the unpacked machine5.2
 Storage of the packed or unpacked machine5.3

Section 6-UNPACKING

Section 7-INSTALLATION

Safety measures7.1
 Space required for machine operation.....7.2
 Machine positioning7.3
 Preliminary electric check-out7.4
 Machine connections to the mains and check-out7.5
 Check-out of phases (for three-phase mains only)7.6
 Pneumatic connection.....7.7

Section 8-CONTROLS

Section 9-SAFETY DEVICES OF THE PNEUMATIC CIRCUIT

Blade guards9.0
 emergency stop button.....9.2
 electric system9.3

Section 10-SET UP AND ADJUSTMENT

Safety10.0
 Tape loading on top unit10.1
 Tape loading on bottom unit10.2
 Start up10.3

Section 11-OPERATION

Operator's correct working position.....11.1
 Starting the machine11.2
 Starting production11.3
 Tape replacement.....11.4
 Other size boxes11.5
 Cleaning11.6
 Safety devices checkout.....11.7
 Trouble shooting.....11.8

Section 12-MAINTENANCE AND REPAIR

Section 13-ADDITIONAL INSTRUCTIONS

Section 14-ENCLOSURES

Section 15-DRAWING AND DIAGRAMS

LIST OF ABBREVIATIONS, ACRONYMS AND UNUSUAL TERMS TO BE FOUND IN THIS MANUAL

| | | |
|----------|---|-------------------------------------------------------------------|
| Dwg. | = | drawing |
| Encl. | = | enclosure |
| Ex. | = | example |
| Fig. | = | figure showing spare parts |
| Max. | = | maximum |
| Min. | = | minimum |
| Mod. | = | machine model |
| N. | = | number |
| N/A | = | not applicable |
| OFF | = | machine stopped |
| ON | = | machine running |
| OPP | = | oriented polypropylene adhesive tape |
| Pict. | = | picture |
| PLC | = | Programmable Logic Control |
| PP | = | polypropylene |
| PTFE | = | Polytetrafluorethylene |
| PVC | = | Polyvinylchloride |
| Ref. | = | reference mark |
| SIAT SPA | = | Società Internazionale Applicazioni Tecniche (Società per Azioni) |
| Tav. | = | Illustration |
| w | = | width |
| h | = | height |
| l | = | length |

1-INTRODUCTION

1.1 MANUFACTURING SPECIFICATIONS

The machine has been designed and manufactured complying with the legal requirements in force at the date of its manufacture.

THE REFERENCE DOCUMENTS ARE:

Directives 98/37/CE, 2006/95 CE, 89/336 CEE, 108/04 CE, 2002/96/CE, 2003/108/CE.

1.2 HOW TO READ AND USE THE INSTRUCTION MANUAL

1.2.1 IMPORTANCE OF THE MANUAL

The manual is an important part of the machine; all information contained herein is intended to enable the equipment to be maintained in perfect condition and operated safely. Ensure that the manual is available to all operators of this equipment and is kept up to date with all subsequent amendments.

Should the equipment be sold or disposed of, please ensure that the manual is passed on.

The electric schemes are enclosures to the manual.

Equipment using PLC controls and/or electronic components will include relevant schematics or programmes in the enclosure, and in addition the relevant documentation will be delivered separately.

1.2.2 MANUAL MAINTENANCE

Keep the manual in a clean and dry place near the machine. Do not remove, tear or rewrite parts of the manual for any reason.

Use the manual without damaging it.

In case the manual has been lost or damaged, ask your after sale service for a new copy, quoting the code number of the document.

1.2.3 CONSULTING THE MANUAL

All pages and diagrams are numbered.

The spare parts lists are identified by the figure identification number. All the notes on safety measures or possible dangers are identified by the symbol:



All the important warning notes related to the operation of the machine are identified by the symbol:



The parts typed in **bold** refer to technical data or technical notes on a specific subject.

With reference to how much contained in this manual the manufacturer declines every responsibility in case of:

- use of the machine not conforming to the national laws on the safety,
- wrong predisposition of the installation site and/or of the supporting structures on which the machine will go to operate,
- defects of tension and power supply e/o of other energetic sources,
- missed or wrong observance of the instructions furnished in this instruction manual,
- changes to the machine non authorized,
- use from personal not trained,
- use of non genuine spare parts,
- use of accessories not authorized,
- God's actions.

1.2.4 HOW TO UPDATE THE MANUAL IN CASE OF MODIFICATIONS TO THE MACHINE

Modifications to the machine are subject to manufacturer's internal procedures.

The user receives a complete and up-to-date copy of the manual together with the machine.

Afterwards the user may receive pages or parts of the manual which contain amendments or improvements made after its first publication.

The user must use them update this manual.

2-GENERAL INFORMATION

2.1 SERIAL NUMBER OF THE MACHINE AND NAME OF THE MANUFACTURER

| | | | | | |
|--------------------------------------|----------------------|-----------------------------------------------------|----------------------|----------------------|--|
| SIAT ■ M. J. MAILLIS GROUP | Part Number | SIATs.p.a.Via G.Puecher N°22 ☎ Turate (CO) ITALY | | | |
| | <input type="text"/> | Volt | Ampere | Year | |
| Model | Serial Number | <input type="text"/> | <input type="text"/> | <input type="text"/> | |
| <input type="text"/> | <input type="text"/> | Watt | Hertz | Phases | |
| Type | Weight kg | <input type="text"/> | <input type="text"/> | <input type="text"/> | |
| <input type="text"/> | <input type="text"/> | <input type="text"/> | <input type="text"/> | <input type="text"/> | |

2.2 FOR AFTER-SALE SERVICE AND SPARE PARTS PLEASE APPLY TO:

| |
|----------------------------------------------------------------------------------------------|
| SIAT ■ M. J. MAILLIS GROUP |
| Via Puecher, 22 22078 TURATE (CO) - ITALY |
| Tel. 02-964951 Fax. 02-9682239 E-mail siat@siat.com |

| |
|--------------------------------------------------------------|
| AGENTE/DISTRIBUTORE O SERVIZIO ASSISTENZA TECNICA LOCALE: |
|--------------------------------------------------------------|

2-GENERAL INFORMATION

2.3 WARRANTY

Within the limits of what is set forth below, Seller agrees to repair or replace without cost to Buyer any defective goods when such defect occurs within a period of twelve (12) months from the date in which Seller's goods have been put into use (Intended use: n 1 turn of job of 8 hours)

Expressly excluded from this warranty are those parts subject to normal wear and tear (by way of illustration, but not limitation, such parts as belts, rubber rollers, gaskets, brushes, etc.) and electrical parts.

Buyer must immediately notify Seller of any defect, specifying the serial number of the machine.

Buyer shall send to Seller the defective item for repair or replacement. Seller will perform the repairs or provide a replacement within a reasonable period of time.

Upon effecting such repair or replacement, Seller shall have fulfilled its warranty obligations. In the event the repairs or replacement must be effected at the place where the machine is installed, all expenses for labor, travel and lodging of Seller's personnel shall be sustained by the Buyer. Buyer will be invoiced in conformity with Seller's standard charges for the services rendered.

Seller is not responsible for defects resulting from:

- Improper use of the machine
- Lack of proper maintenance
- Tampering with the machine or repairs effected by the Buyer.

Seller will not be liable for any injury to persons or things or for the failure of production. With respect to the materials not manufactured by Seller, such as motors and electrical equipment, Seller will grant to Buyer the same warranty Seller receives from its supplier of such materials. Seller warrants the compliance of its machines with the laws of EEC and non-EEC countries in which the machines may be installed, it warrants compliance with laws or standards relating to the prevention of accidents or pollution.

Adaptation of Seller's machines to special laws or standards of the country of installation shall be the responsibility of Buyer who assumes all liability therefore.

Buyer shall indemnify and hold Seller harmless against any claim by third parties resulting from failure to comply with the aforesaid laws and standards.

3-SAFETY INFORMATION

3.1 GENERAL SAFETY INFORMATION

Read all the instructions carefully before starting the work with the machine; please pay particular attention to sections marked by the symbol:



Keep this manual in a handy place near the machine: its information will help you to maintain the machine in good and safe working condition.

3.2. DEFINITION OF THE OPERATORS' QUALIFICATIONS

- Machine operator
- Maintenance technician
- Electrician
- Manufacturer's technician

Only persons who have the skills described in the following page should be allowed to work on the machine. It is the responsibility of the user to appoint the operators having the appropriate skill level and the appropriate training for each category of job.

SKILL 1

MACHINE OPERATOR



Operator trained and qualified for the operation of the machine using the general switch and emergency stop, box introduction, make adjustment of dimension machine for different case size, to change tape, starting, stopping and restarting the machine in case of interruption of the cycle.

NOTE: The supervisors of the factory and the foremen will make sure that the machine operator has been trained to all operations before starting to operate the machine.

SKILL 2

MECHANICAL MAINTENANCE TECHNICIAN



This operator is trained to use the machine as the MACHINE OPERATOR and in addition is able to work with the safety protection disconnected, to check and adjust mechanical parts, to carry out maintenance operations and repair the machine.

He is not allowed to work on live electrical components.

SKILL 2a



ELECTRICAL MAINTENANCE TECHNICIAN

This operator is trained to use the machine as the MACHINE OPERATOR and in addition is able to work with the safety protection disconnected, to make adjustments, to carry out maintenance operations and repair the electrical components of the machine.

He is allowed to work on live electrical panels, connector blocks, control equipment etc.

SKILL3

SPECIALIST FROM THE MANUFACTURER



Skilled operator sent by the manufacturer or its agent to perform complex repairs or modifications, when agreed with the customer.

3-SAFETY INFORMATION

3.3 INSTRUCTIONS FOR A SAFE USE OF THE MACHINE

Only persons who have the skills described on the following paragraph 3.6 are allowed to work on the machine.

It is responsibility of the user to appoint the operators having the appropriate skill level and the appropriate training for each category of job.

3.4 STATE OF THE MACHINE

List of the modes which are possible with this machine:









- stopped with electric power disconnected;
- stopped with main switch on '0' (OFF) position,
- stopped with emergency button,
- running with main switch on '1' (ON) position,

3.5 NUMBER OF THE OPERATORS

The operations described hereinafter have been analyzed by the manufacturer; the number of operators shown for each operation is suitable to perform it in the best way. A number of operator below or above can endanger the safety of personal.

3.6 OPERATORS' SKILL LEVELS

The table below shows the minimum operator's skill for each operation with the machine.

| OPERATION | MACHINE MODE | OPERATORS SKILL | OPERATORS NUMBER |
|---------------------------------------|------------------------------------------------|---------------------------------------------------------------------------------------|------------------|
| Installation and se-up of the machine | Running with safety protections disabled |  | 2 |
| Adjustment of the box size. | Stopped by pressing the EMERGENCY STOP button. |  | 1 |
| Tape replacement . | Stopped by pressing the EMERGENCY STOP button. |  | 1 |
| Blade Replacement . | Electric power disconnected |  | 1 |
| Driver belts substitution | Electric power disconnected |  | 1 |
| Ordinary mechanical maintenance | Electric power disconnected |  | 1 |
| Ordinary electric maintenance | Electric power disconnected |  | 1 |
| Extraordinary Electric maintenance | Stopped by pressing the EMERGENCY STOP button. |  | 1 |

3-SAFETY INFORMATION

3.7 RESIDUAL HAZARDS

The case sealer has been designed following the CE directives, and incorporates various safety protections which should never be removed or disabled.

Notwithstanding the safety precautions conceived by the designers of the machine, it is essential that the operator and service personnel be warned that the following uneliminable residual hazards exist:

WARNING! Tape cutting blades.

Never remove the safety device which covers the blade on the top and bottom taping units.

Blades are extremely sharp. Any error may cause serious injuries

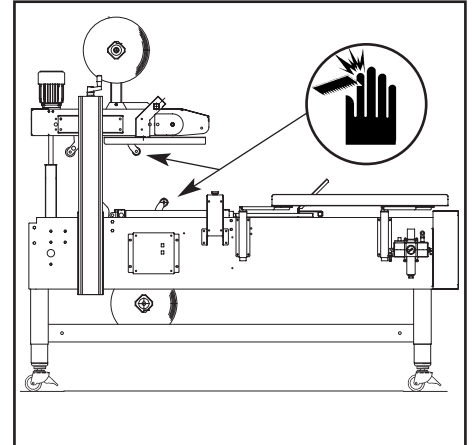

WARNING! Lateral Guides.

Never push the box when it is driven from driver belt.

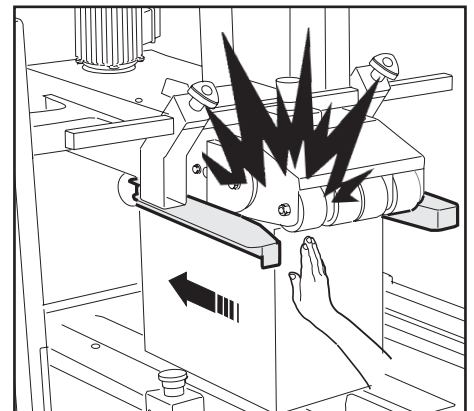

WARNING! Upper and lower drive belts.

Never work on the machine with loose hair or loose garments such as scarfs, ties or sleeves.

Although protected, the drive belts may be dangerous.

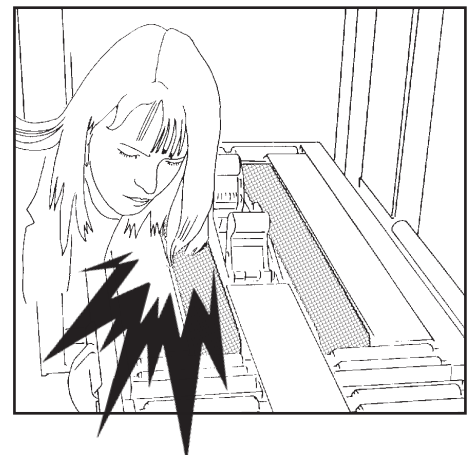

3-SAFETY INFORMATION

WARNING! Top driving belts.

Never touch the running belt with your hands.
Serious injury may occur.

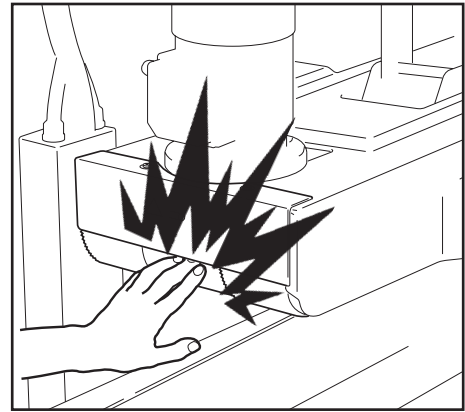

WARNING! Left/Right flap folder cam

Do not introduce any part of the body between the side flap folder cams and do not press with your hands.
Danger to be squashed!

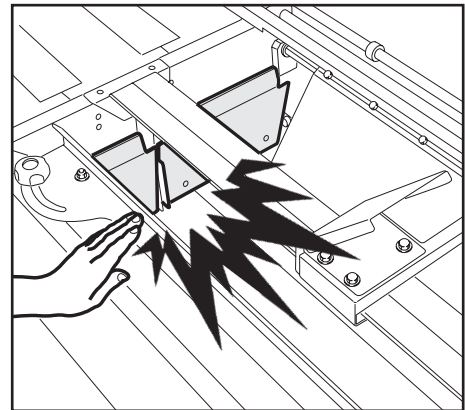

WARNING! Left/Right flap folder panel

Do not introduce your hands between the box-holder guide and the flap folder device. Danger to be squashed.
Danger to be squashed!

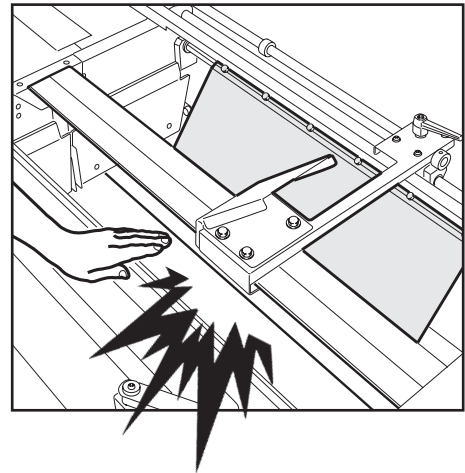

3.8 PERSONAL SAFETY MEASURES

(Safety glasses, safety gloves, safety helmet, safety shoes, air filters, ear muffs).
None is required, except when recommended by the user.

3.9 PREDICTABLE ACTIONS WHICH ARE INCORRECT AND NOT ALLOWED

- Never work without the safety protections.
- Only authorised personnel should be allowed to carry out the adjustments, repairs or maintenance which require operation with reduced safety protections. During such operations, access to the machine must be restricted. When the work is finished, the safety protections must immediately be reactivated.
- The cleaning and maintenance operations must be performed after disconnecting the electric power.
- Do not modify the machine or any part of it. The manufacturer will not be responsible for any modifications.
- Follow carefully the installation instructions of this manual.

3-SAFETY INFORMATION

3.10 TABLE OF WARNINGS, LABELS, PLATES AND DRAWINGS TO BE FOUND ON THE MACHINE

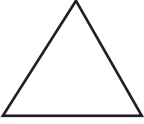
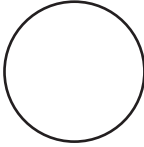
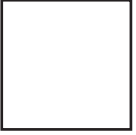
| | SYMBOLS | COLOURS |
|-----------------------------------------------------------------------------------|--------------------------------|-------------------|
|  | DANGER AND PARTS IN MOVEMENT | YELLOW COLOUR |
|  | COMPULSORY ACTIONS/PROHIBITION | RED COLOUR |
|  | CONTROLS AND INFORMATION | LIGHT BLUE COLOUR |

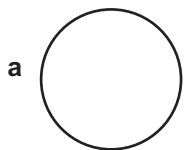

Before starting any maintenance operations the electrical power must be disconnected.

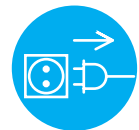

Label code: S300109996A



Caution! high voltage



Label code: S300110096A



Show the earth wire connection point on the machine frame.



Label code: S300103996A



Identification data for the machine model, serial number and manufacturer.

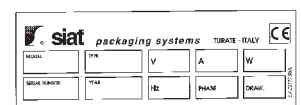

Label code: S340277700A

3-SAFETY INFORMATION

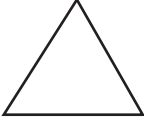
e  Warns the operator not to introduce the hands into the cavities of the box side guides.



Label code: 3.0.01068.96A

f  Tape threading path for top and bottom taping unit, and position of the sharp knife.

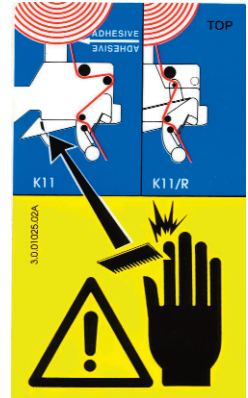

Label code: 3.0.01025.02A

g  Position to move the machine with forklift.

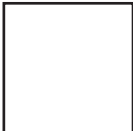

Label code: SBC0010337

h  Show the running direction of the belts.



Label code: 3.0.01040.96A

i  Shows the danger of the upper drive belts when running



label code: 3.0.01030.96A

l  Show the danger of the bottom drive belts when running.



Codice etichetta: 3.0.01031.96A

4-PRELIMINARY INFORMATION ON THE MACHINE

4.1. GENERAL DESCRIPTION OF THE MACHINE

Station of packing and sealing. Composed from a forming section with cylinder pusher and a sealing section with driving belt to the packing different size of boxes.

This station allow a height regulation of the work plan. Different combination can be obtained with accessories AS77 (with wheels) and AS80 (legs).

4.2. TECHNICAL SPECIFICATIONS

- Production= 480÷600 box/hour
- Standard power supply= 230/400 V, 50 Hz 3Ph
- N. 2 motors 0,13 kW
- Taping units K11, tape width 50 mm
- Weight = 225 kg
- Belts speed= 22 m/minuto
- Compressed air= max. 6 bar, 7 l/cycle

4.3 TAPE DIMENSIONS

Suitable adhesive tapes:

PVC

OPP

ADHESIVE PAPER

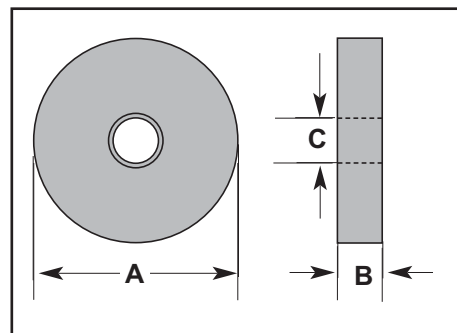

A = 410 mm max
B = 50 mm
C = 76 mm

4.4 PURPOSE OF THE MACHINE

The machine is designed to seal with adhesive tape cases having the dimensions (in millimeters) shown in section 4.5, by applying two tape stripes on their top and bottom flaps simultaneously.

The machine supplied with the standard electric system is not designed for use in atmosphere with risk of deflagration. In such conditions the machine must be equipped with anti-deflagration components and/or air motors.

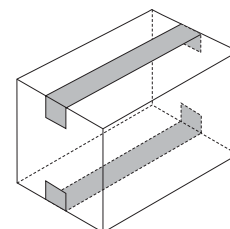

4.5 BOX SIZE RANGE

The machine can form and to close boxes automatically any box sizes included in the range shown below:

l x w x h (min.) = 200 x 150 x 120 mm

l x w x h (max.) = 600 x 500 x 500 mm

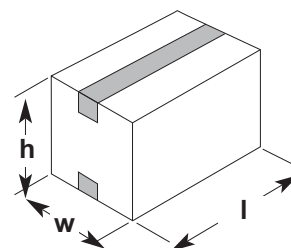

4-PRELIMINARY INFORMATION ON THE MACHINE

4.6 MAIN COMPONENTS

The machine is composed from: N. 1 base , N. 4 adjustable legs, N. 2 columns , N. 2 tape units, N. 1 top head, N. 1 top motorization, N. 1 bottom motorization, N. 2 electric motors, N. 1 former unit with closing flaps, N. 1 emergency button N. 1 main switch.

4.7 OPERATIVE FLOW

The machine fold automatically bottom flap of the box manually insert by operator into forming section. The carton, with bottom flaps closed, is held in upright position for filling. The box is push by means of a pneumatic device into the case sealer unit for simultaneous top and bottom sealing and thah sent on outfeed conveyor, if installed.

Environmental condition required:

- Temperature min. +5 °C, max. +40 °C,
- Umidity min. 30%, max. 80%, without condensate.
- Dust free environment..
- Altitude: 1000 m a.s.l.

4.8 OVERALL DIMENSIONS

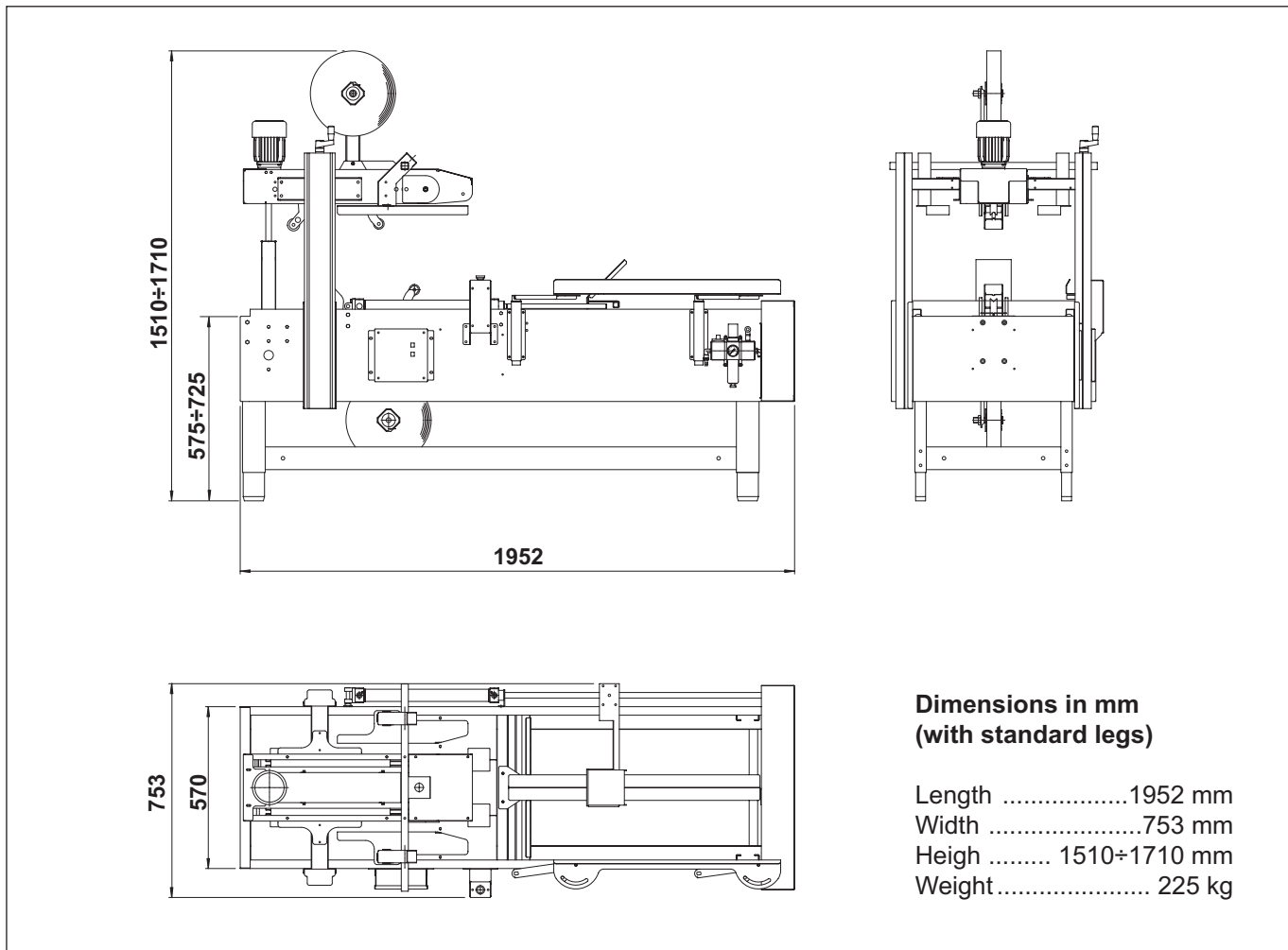

4.9 MACHINE NOISE MEASUREMENT

Acoustic pressure at 1 meter distance from the machine with the tape roll inserted: 73 dB. Acoustic pressure at a height of 1,6 meter above the machine with the tape roll inserted: 73 dB. The measurement has been performed by a SPYRI-MICROPHON phonometer.

4-PRELIMINARY INFORMATION ON THE MACHINE

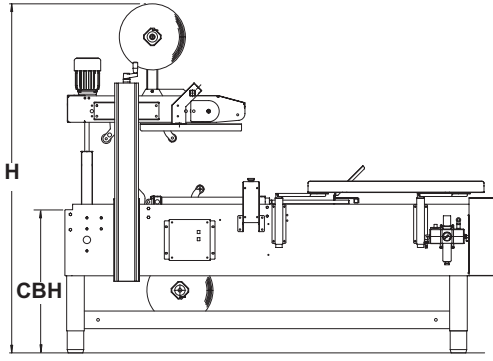
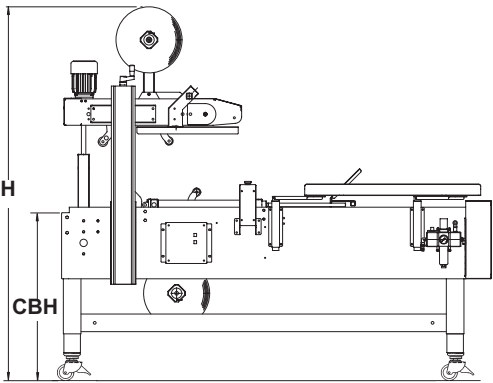
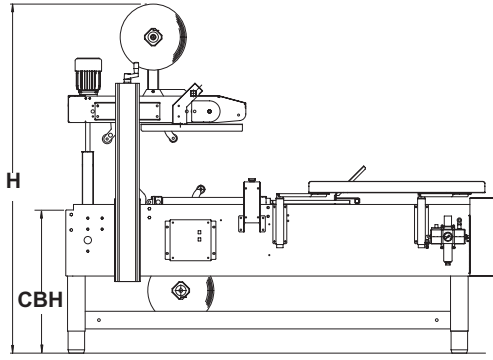
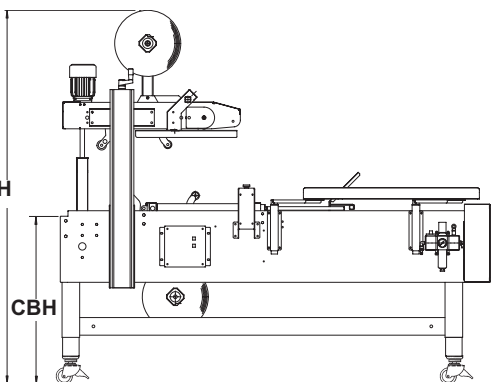
| | | | | | |
|-------------------------------------------------------------------------------------|----------------------------------------------|------------|--------------------|-------------|-------------|
|  | A WITH STANDARD LEGS | | | | |
| | CONVEYOR BED HEIGHT | | OVERALL DIMENSIONS | | |
| | MIN | MAX | | MIN | MAX |
| CBH | 575 | 725 | H | 1510 | 1710 |
| | | | L | 1952 | 1952 |
| | | | W | 753 | 753 |
|  | B WITH AS77 CASTERS (OPTIONAL) | | | | |
| | CONVEYOR BED HEIGHT | | OVERALL DIMENSIONS | | |
| | MIN | MAX | | MIN | MAX |
| CBH | 675 | 825 | H | 1610 | 1810 |
| | | | L | 1952 | 1952 |
| | | | W | 753 | 753 |
|  | C WITH OPTIONAL LEGS | | | | |
| | CONVEYOR BED HEIGHT | | OVERALL DIMENSIONS | | |
| | MIN | MAX | | MIN | MAX |
| CBH | 735 | 885 | H | 1670 | 1870 |
| | | | L | 1952 | 1952 |
| | | | W | 753 | 753 |
|  | D WITH OPTIONAL LEGS AND AS77 CASTERS | | | | |
| | CONVEYOR BED HEIGHT | | OVERALL DIMENSIONS | | |
| | MIN | MAX | | MIN | MAX |
| CBH | 745 | 985 | H | 1770 | 1970 |
| | | | L | 1952 | 1952 |
| | | | W | 753 | 753 |

5-SHIPPING-HANDLING-STORAGE

5.1 SHIPMENT AND HANDLING OF THE PACKED MACHINE

The machine is fixed on the pallet with four bolts and can be uplifted by using a forklift.

The packing is suitable to travel by land and by air.

Optional seafreight packing available.

PACKING OVERALL DIMENSIONS

l = length 202 cm

w = width 84 cm

h = height 150 cm

Weight 250 kg

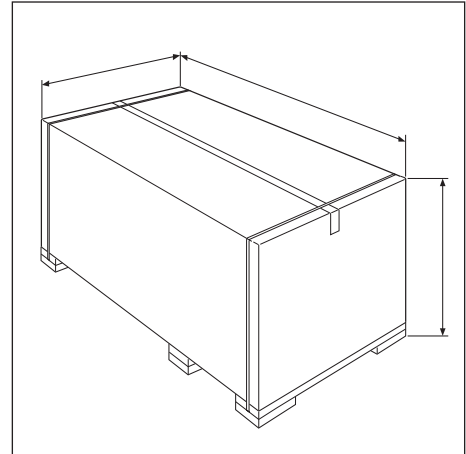

5.2 SHIPMENT AND HANDLING OF THE UNPACKED MACHINE



The unpacked machine can only be moved for short distances and indoor only. The transportation of the machine without packaging may cause damages and accidents.

l = length 192,5 cm

w = width 75,3 cm

h = height 1510 cm

Weight 225 kg

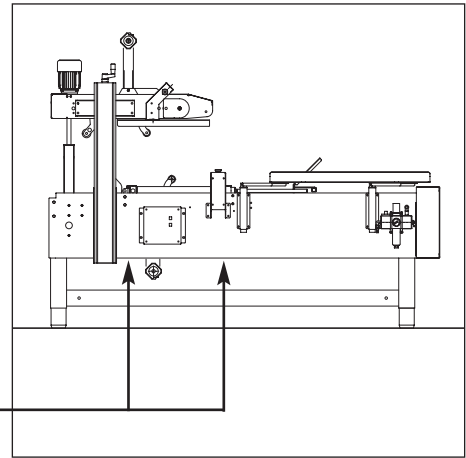

5.3 STORAGE OF THE PACKED OR UNPACKED MACHINE

In case the machine must stay inactive for a long period, please take the following precautions:

- store the machine in a dry and clean place;
- if the machine is unpacked it is necessary to protect it from the dust and do not stack anything over the machine;

6-UNPACKING

- 6.1 The envelope placed on the external side of the packing contains the instructions concerning the unpacking of the machine.

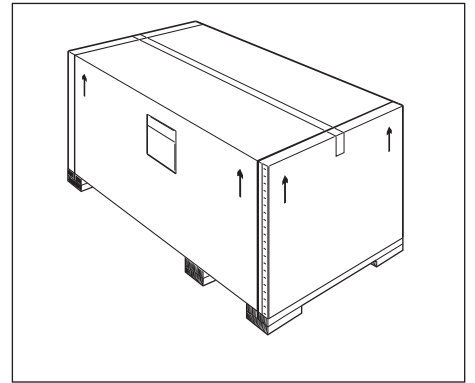

Machine layout inside the packing.
Cut the polypropylene straps. Use a cutter to remove the part of the carton fixed by the staples along the entire perimeter of the packing.
(Otherwise remove the staples by using a suitable tool)

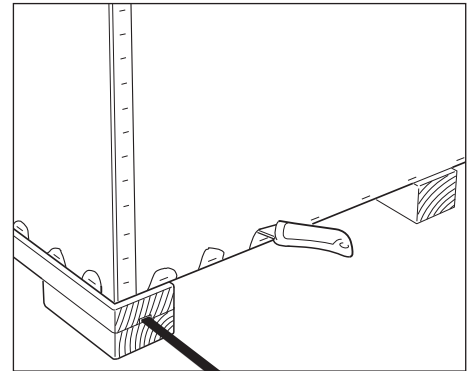

After having cut the carton or removed the staples, uplift the packing in order to free the machine. (2 persons)

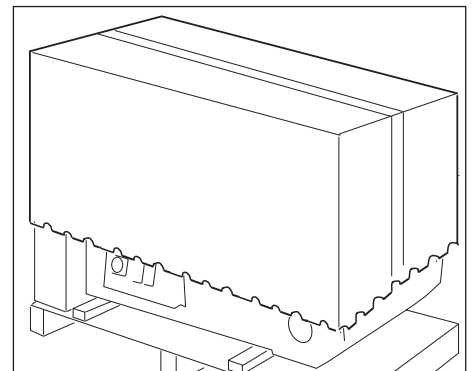

Use a forklift to carry the machine to its working location.
(Weight of machine + pallet = kg 250).

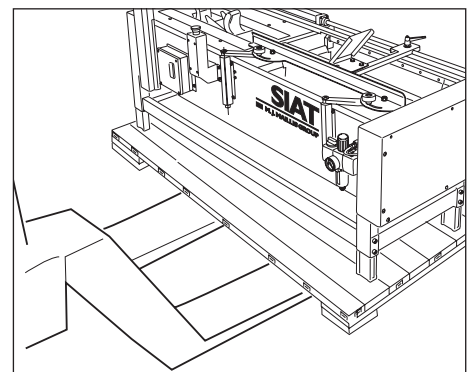

6-UNPACKING

Unscrew the nuts and remove the brackets which fix the machine to the pallet.

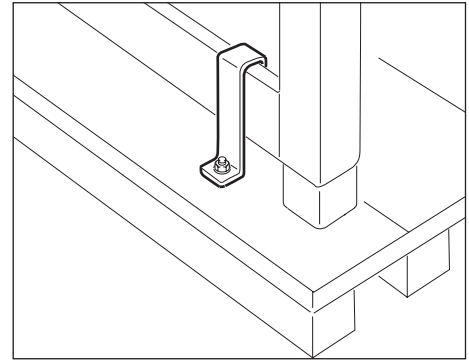

After brackets removing lift the machine with a fork truck placing the forks as suitable in picture.

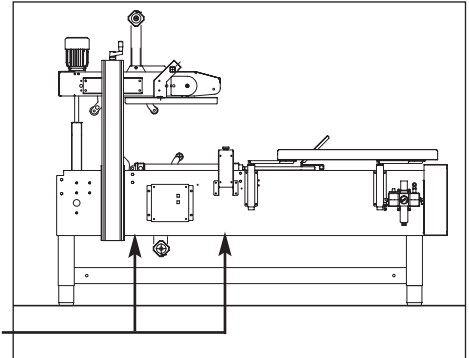

6.2 PACKING DISPOSAL

The packing of the machine is composed of:

- wooden pallet
- carton box
- wooden supports
- steel fixing brackets
- polythene foam protection
- plastic straps (PP)
- clay dehydrating pouches (only for seafreight shipments)
- aluminum/polyester/polythene bag (only for seafreight shipments)

For the disposal of these materials please follow the provisions of the law in your country.

7-INSTALLATION

7.1. SAFETY MEASURES

Read carefully chapter 3.

7.2. SPACE REQUIRED FOR MACHINE OPERATION AND MAINTENANCE

Min. distance from the wall **A= 1000 mm**, **B= 700 mm**
height min.= **2500 mm**

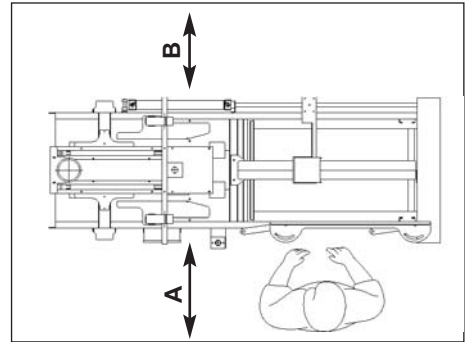

7.3 MACHINE POSITIONING

Lift the machine with a fork truck, placing the forks in the indicated points.

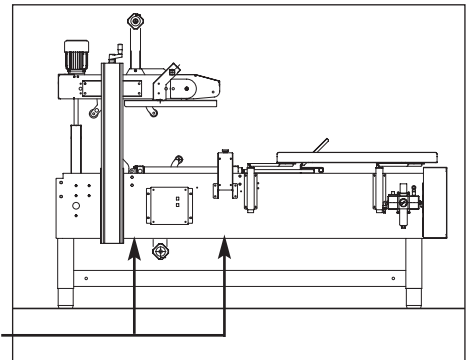

7.3.1 ADJUSTEMENT HIGHT WORK PLANE

Lift the machine as shown in Picture.

Unlock the screws and take the legs out looking for the desired conveyor bed height on the graduated label; Then lock the screws again.

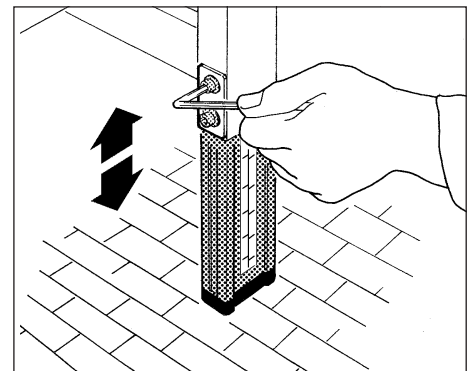

7.4 PRELIMINARY ELECTRIC CHECK-OUT

Before connecting the machine to the mains please carry out the following operations:

- Check if the socket is equipped with circuit protection
- Make sure that the socket is provided with a ground protection circuit and that both the mains voltage and frequency meet the indications on the name plate.
- Check that the connection of the machine to the mains meets the provisions of law and/or the safety regulations in your country.

7.5 MACHINE CONNECTION TO THE MAINS AND CHECK-OUT

- Check that main switch is in '0' (OFF) position.
- Connect the cable supplied with the machine to a plug which complies with the safety regulation of your country installation site.
- Connect the plug to the mains.

7-INSTALLATION

7.6 CHECK-OUT OF PHASES

Procedure to be followed in order to connect correctly the position of the phases:

- Remove any tools from the conveyor bed.
- Release the lockable emergency stop button turning it clockwise.
- Push button ON of the main switch.
- Check the rotation direction of the side drive belts.
- In case they rotate in the wrong way, please reverse 2 phases on the plug.

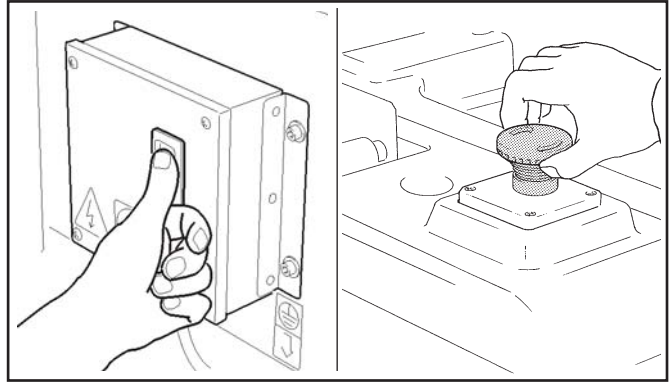

Correct drive belts direction.

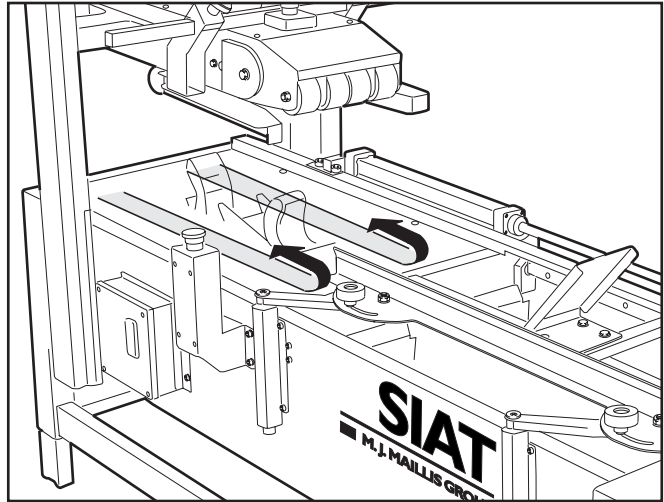

7.7 PNEUMATIC CONNECTION

Connect a 8 mm hose with hose clamp supplied as in picture.

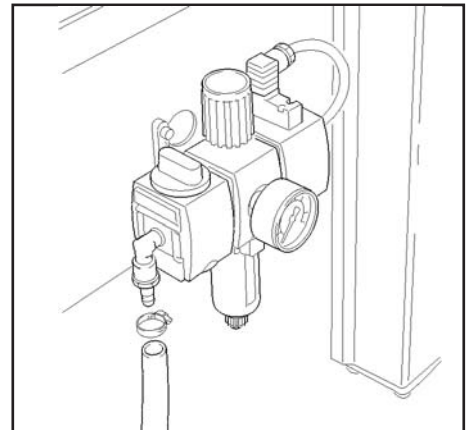

Switch on the pneumatic circuit with knob 1.

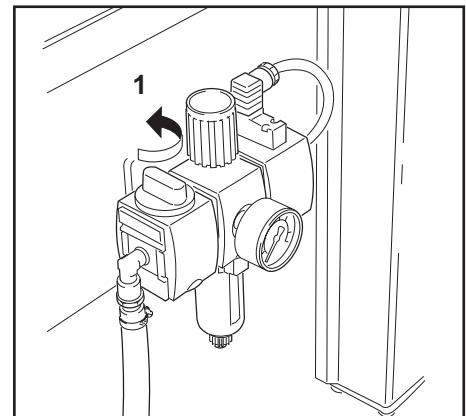

8-CONTROLS

8.1 BUTTON OF START/STOP (1)

It starts/stops the box drive belts..

EMERGENCY STOP BUTTON (2)

It stops the machine cycle.

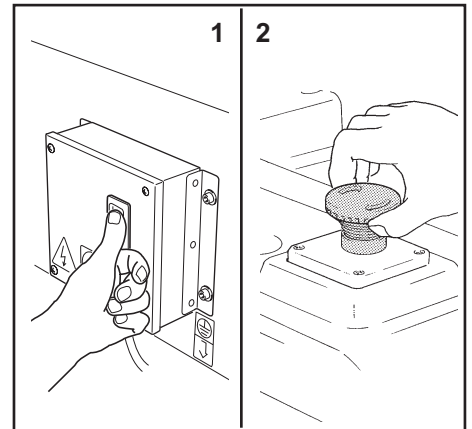

8.2 BOX HEIGHT ADJUSTMENT CRANK

It adjusts the upper head according to the box height.

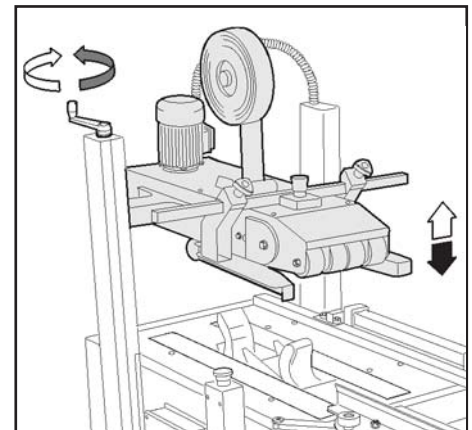

8.3 BOX WIDTH ADJUSTMENT KNOBS

It adjusts the side guides according to the box width.

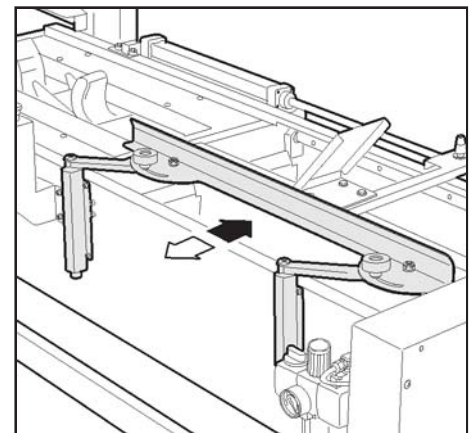

8.4 LATERAL FLAP COMPRESSION

Locks / unlocks the flap compression.

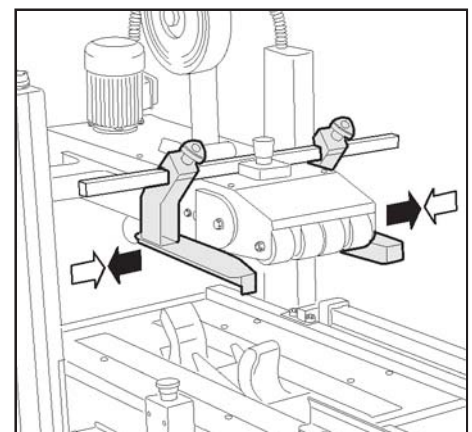

8-CONTROL

8.5 FEEDING VALVE FOR THE PNEUMATIC CIRCUIT

Activates/desactivates the pneumatic installation.

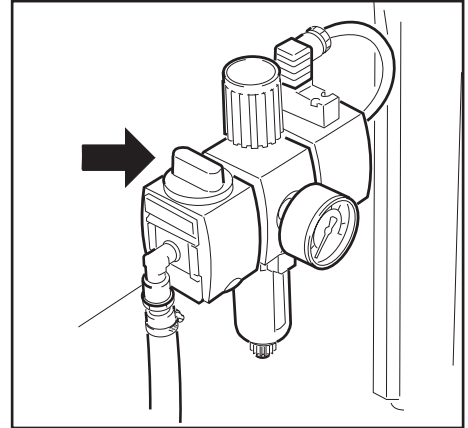

8.6 KNOB ADJUST THE PRESSURE IN THE PNEUMATIC CIRCUIT

Increase / decrease the pressure.

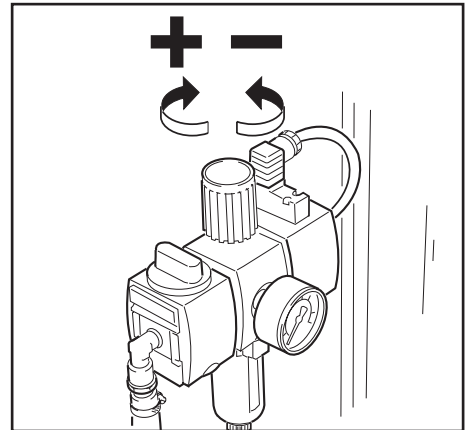

8.7 PUSHER CYLINDER START BUTTON

Insert the box in forming part and press this to eject the box after forming.

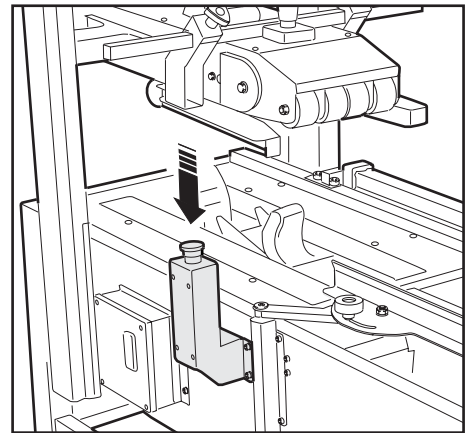

9-SAFETY DEVICES OF THE MACHINE

9.1 BLADE GUARDS

Both the top and bottom taping units have a blade guard.

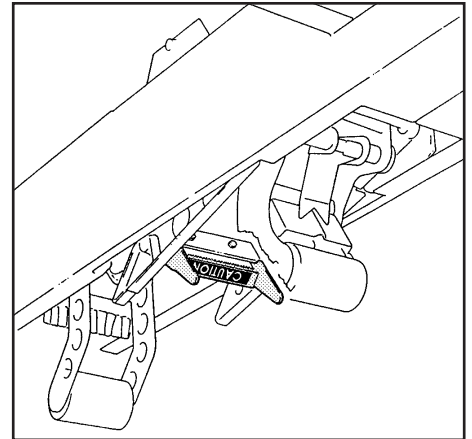

9.2 EMERGENCY STOP BUTTON

The lockable emergency stop button is placed in handy position.

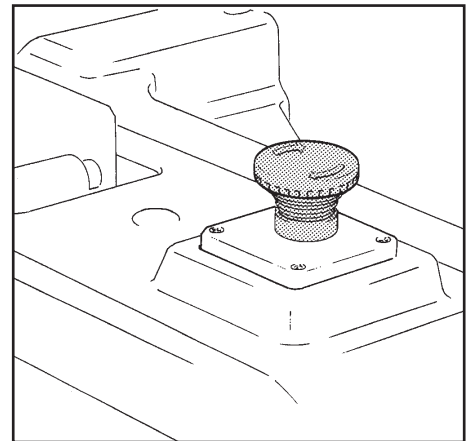

9.3 ELECTRIC SYSTEM

The electric system is protected by a ground wire whose continuity has been factory- tested during the electrical test. The system is also subject to insulation and dielectric strength tests.
(See section attachment)

10-SET-UP AND ADJUSTMENTS

10.0 SAFETY

All the set-up operations and adjustments must be carried out when the machine is stopped and the EMERGENCY STOP BUTTON is locked.

OPERATION MADE OPERATOR

10.1. TAPE LOADING ON THE TOP UNIT

Turn the knob **1** to activate the pneumatic circuit and raise the upper head assembly by turning clockwise the selector **2**.

Insert a tape roll on the drum and push it fully forward.

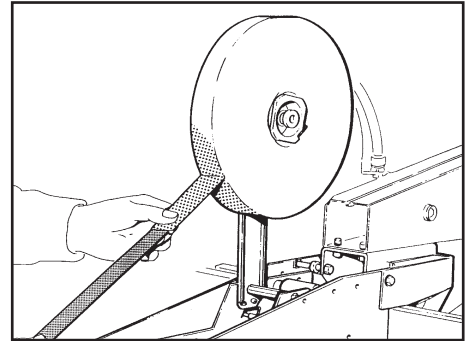
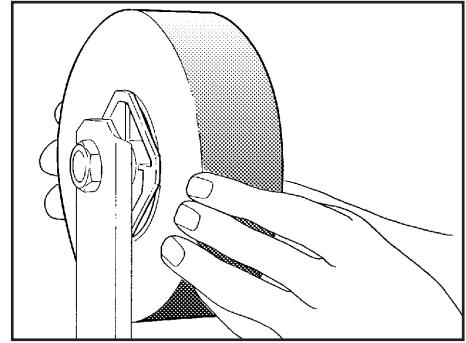

Insert the plastic threading leader through the taping unit. Take care to keep hands away from the tape cutting blades. (see section **3.11-g**).

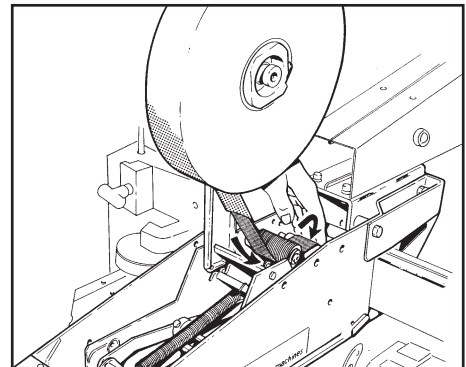

Follow the path through the unit as shown on Picture and make sure that the adhesive side is placed on the correct side.

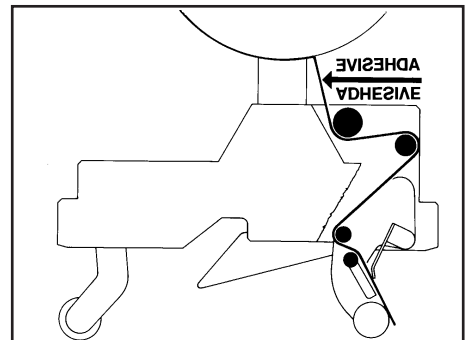

Pull and cut off the tape in excess.

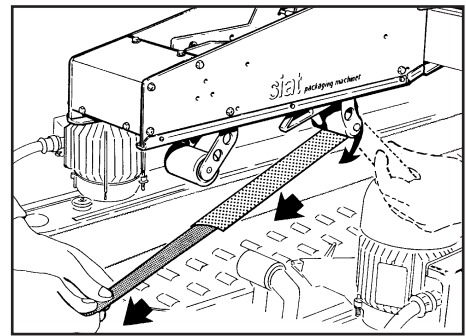

10-SET-UP AND ADJUSTMENTS

10.2 TAPE LOADING ON THE BOTTOM UNIT

Remove the bottom taping unit from its housing and put it on a working bench.

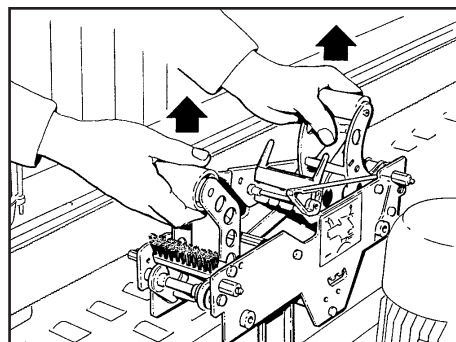

Put a tape roll on the drum and to make the same operation indicated of top unit

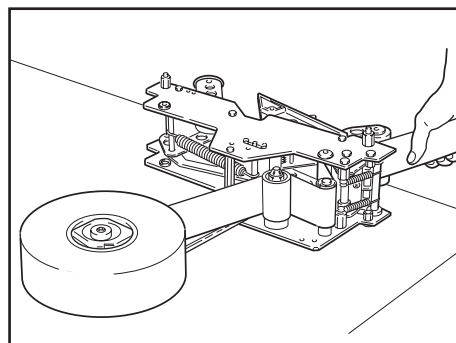

Put again the taping head into its seat.

TAPE DRUM ALIGNMENT

Check the centering of the tape on the rollers of the taping unit. If needed, unlock bolt 1 and adjust screw 2.

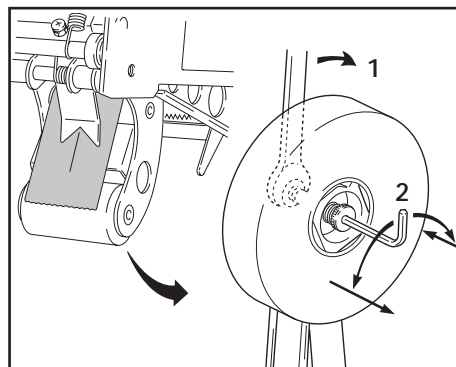

TAPE DRUM FRICTION BRAKE ADJUSTMENT

Check the tape tension:

- with PVC tape the drum must be free
- with OPP tape the drum must be slightly frictioned

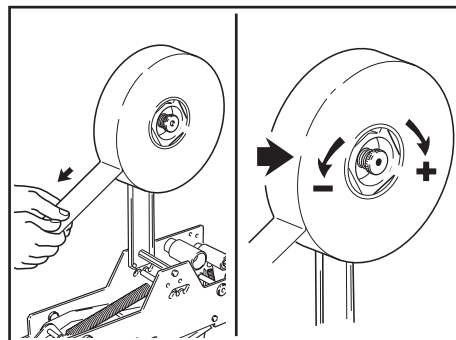

ADJUSTMENT OF TAPING UNITS ACCORDING TO THE TYPE OF BOXES

Adjust the main spring:

- decrease the spring load for lightcardboard cases;
- increase the spring load for robustcardboard cases.

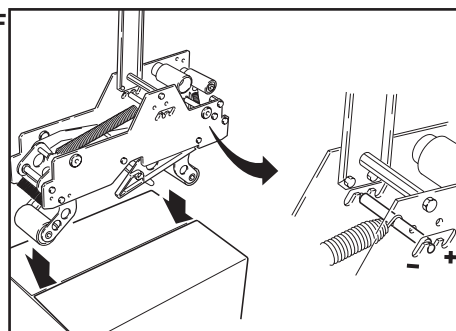

10-SET-UP AND ADJUSTMENTS

10.3 START UP

MACHINE OPERATOR



Press "ON" on main switch (A); Switch "ON" the pneumatic system (B).

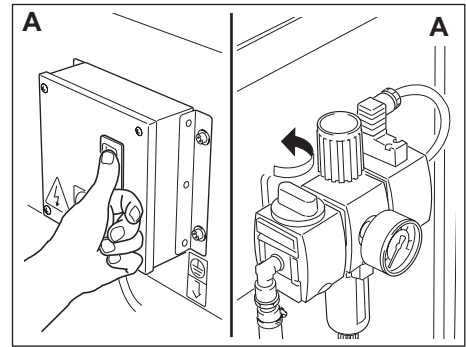

Open the box, with the front and back bottom flaps folded in, into the Case Former center guide (see the picture)

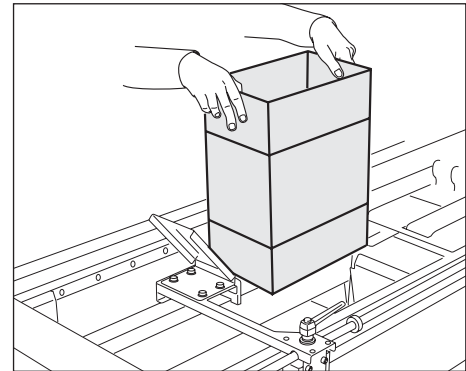

Insert box slightly inclined into the machine so to fold the front flap with the central guide (see the picture).

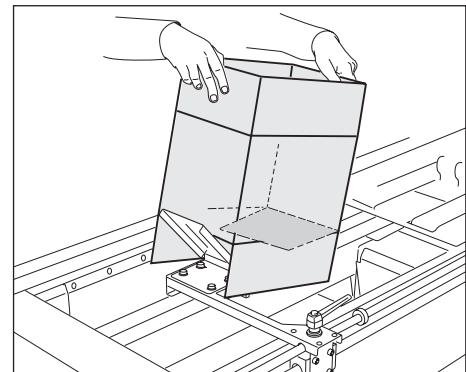

Put the rear flap against the pusher plate and give some pressure so to fold the flap and let the box slide on the central guide

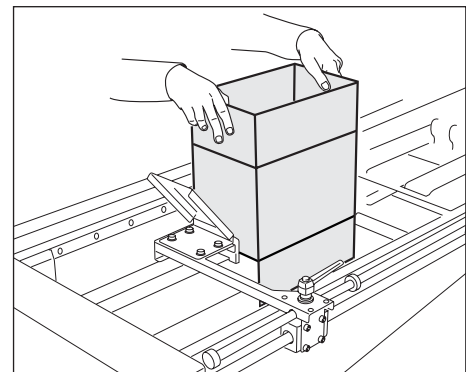

The operator moves the box forward until the bottom flaps contact the bottom flaps actuator plates. At the same time the two flaps close the the box.

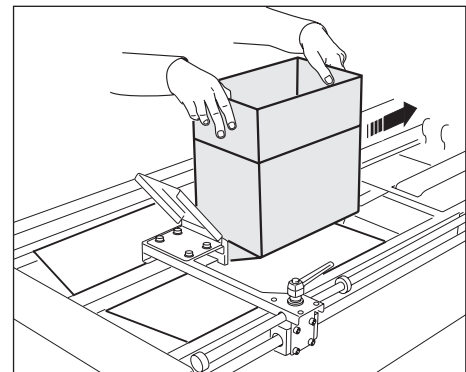

10-SET-UP AND ADJUSTMENTS

Loose the pusher locking device and place the slipway against the box in order to optimize the race of the cylinder rod according to the length of the box.

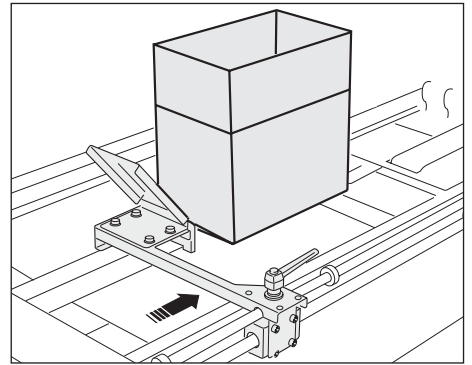

Adjust the position of the lateral guide checking the box centering on the central line.

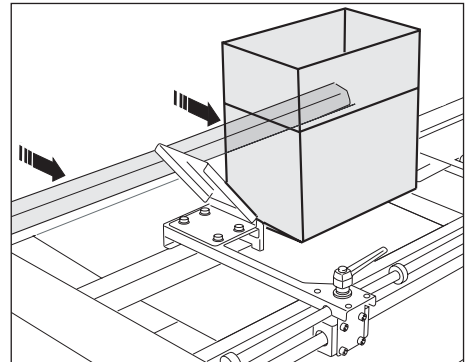

Fill the box and then fold up the upper flaps

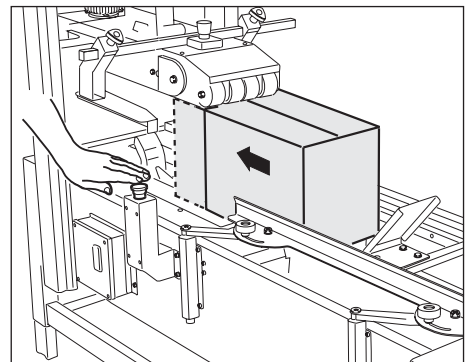

Introduce the box in unit sealing section

Push the operation button pusher driver cylinder.

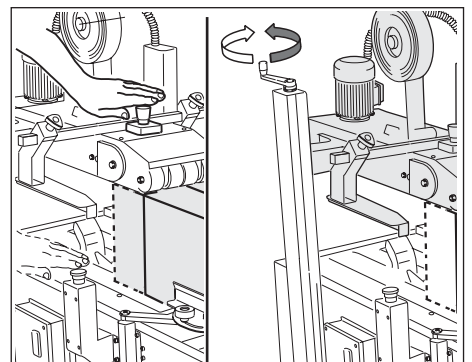

Adjust box height..

Push the mushroom button for the emergency stop as soon as the box touch the upper head

Take down the head acting on special handle up to contact to the same box.

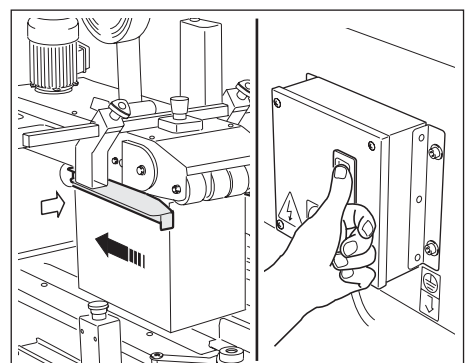

Adjustment of the lateral pressing unit

Place the pressing unit order to have a correct approaching of the upper flap of the box.

Re-set the emergency stop therefore restart the machine pushing the start button completing in this way the sealing box operation.

Start evenly the production as request.

11-OPERATION

11.1 OPERATOR'S CORRECT WORKING POSITION

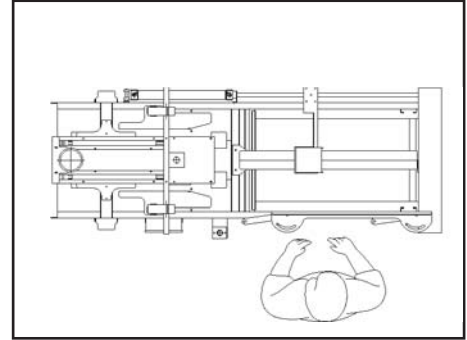

11.2 STARTING THE MACHINE

Push the main switch ON.

11.3 STARTING PRODUCTION

After having adjusted the machine according to the box dimensions (height-width), let the machine idle for a while and check its safety devices (see section 11.7). Then start the working cycle.

11.4 TAPE REPLACEMENT

Be careful with the blades !



Skill operator



When needed, replace the tape roll, as follows:

- Press the LOCKABLE EMERGENCY STOP BUTTON;
- Repeat all the operations shown in sections 10.1 and/or 10.2

11.5 OTHER SIZE BOXES

Repeat all operations in paragraph 10.3

11.6 CLEANING

Before carrying out any cleaning or maintenance operation stop the machine by pressing the OFF button on the main switch.



Disconnect the electric power.



CLEANING - Skill 1 operator

Use dry clothes or light detergents.

Do not use solvents or water jets.

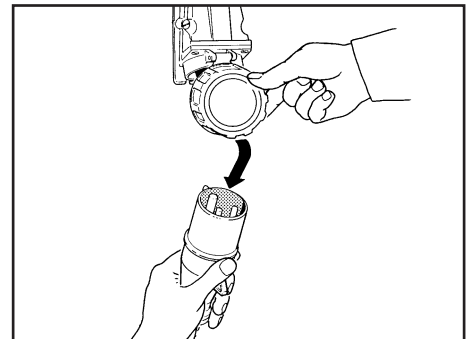
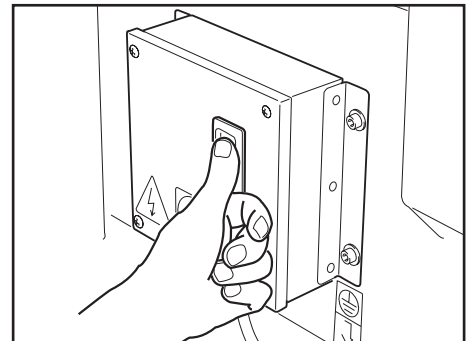

11-OPERATION

11.7 SAFETY DEVICES CHECKOUT

- 1 Taping units blade guard (section 10.1)
- 2 Lockable emergency stop button (section 10.1)
- 3 STOP (OFF) button on main switch (sections 7.11.3 and 9.1)

11.8 TROUBLE SHOOTING

Skill maintenance technician



| TROUBLE | CAUSE | SOLUTION |
|----------------------------------------------------------|------------------------------------------------------------------------------------------|----------------------------------------------------------------------------------------------------|
| When pressing the ON button, the machine does not start. | The lockable emergency stop button is pressed. Short circuit in the electrical system | Release the emergency stop button by turning it anticlockwise. Check the electrical system. |
| The magnetothermic protection opens the main switch | Motor overload . Thermal cut-out not at correct amperage setting. | Check that the drive belts are not blocked Set the correct amperage. |
| The motor runs but the side drive belts stop | Belts tension too low. Worn out drive pulleys. | Adjust belt tension. Check the wear of the rings and replace them when necessary. |
| Drive belts turn but do not convey the box. | Worn out belts . Lateral guides too close | Replace drive belts. Adjust guides position |

12-MAINTENANCE AND REPAIRS

12.1 RECOMMENDED FREQUENCY OF CHECK-OUTS AND MAINTENANCE OPERATIONS

| OPERATIONS | FREQUENCY | OPERATOR'S SKILL |
|--------------------------------------|-----------|------------------|
| Lubrication | Quarterly | 2 |
| Blade Cleaning | Weekly | 2 |
| Machine cleaning | Weekly | 1 |
| Checkout of safety device | Daily | 1 |
| Compressed air unit condensate drain | Daily | 1 |
| Blade replacement | // | 2 |
| Side drive belts replacement | // | 2 |

12.2 CHECK-OUT TO BE PERFORMED BEFORE AND AFTER EVERY MAINTENANCE OPERATION

Before every maintenance operation press OFF button on the main switch and remove the plug from the socket. During the maintenance operation only the operator responsible of this must work on the machine. At the end of every maintenance operation must check the safety devices.

12.3 SAFETY DEVICES CHECK-OUT

1 Blade protection on units tape, 2 Lockable emergency stop button, 3 STOP (OFF) button on main switch.

12.4 MACHINE LUBRICATION



Lubricate every month the guide of carton pusher

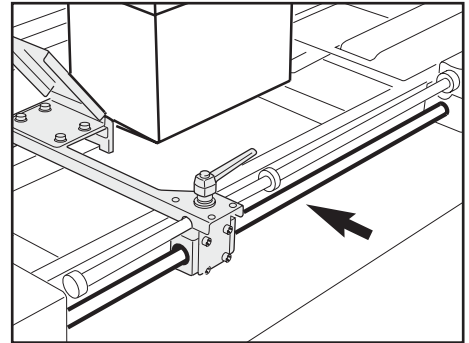

Lubricate quarterly the column's screw

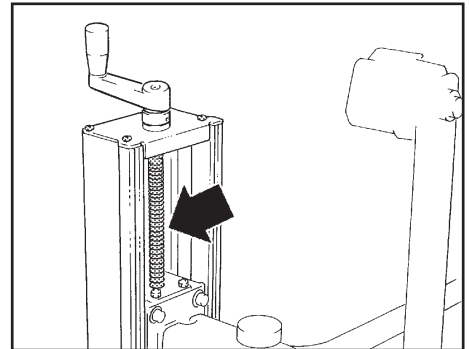

Lubricate closing lateral flaps device chain

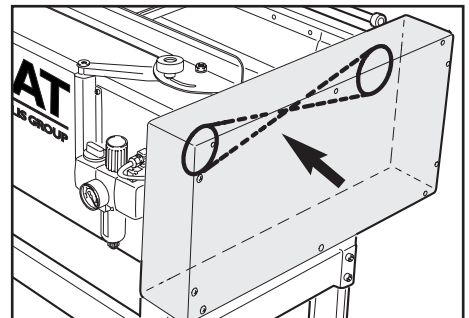

12-MAINTENANCE AND REPAIRS

12.5 SUGGESTED PRODUCTS FOR LUBRICATION

GREASE TYPE:

METAL/METAL: B.C.190 HEAVY DUTY (otherwise grease for chains and bearings)

METAL/PLASTIC: PLATE MASTER M+L (molybdenum grease and PTFE for plastic and metallic materials)

OIL TYPE:

regular lubricating oil or general purpose spray lubricant.

12.6 LUBRICATION OF THE TAPING UNIT

Lubricate monthly with oil the points shown on Picture.

- A spring holder pin
- B spring tension pin
- C roller shaft
- D cutter hinge
- E blade guard pin

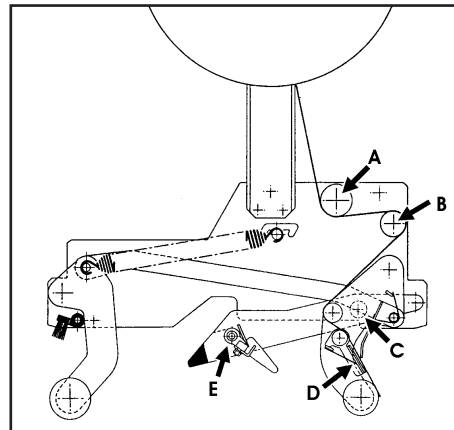

12.7 BLADE CLEANING



Skill operator

Lift the blade guard and clean the blade by using a brush (with a long handle) and some oil. The oil prevents the adhesive clotting.

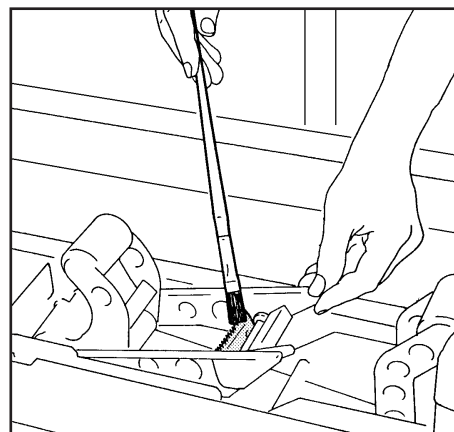

12.8 BLADE REPLACEMENT

Skill operator

- Lift the blade guard as shown in Picture
- Release the screws.
- Remove the blade.

WARNING!

Very sharp blade.

Any error may lead to bad injuries.



- Insert the new blade paying attention to the position of its sharp side.
- Fix the screws.
- Release the guard.

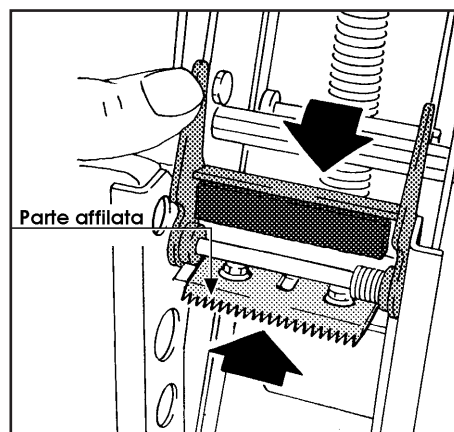
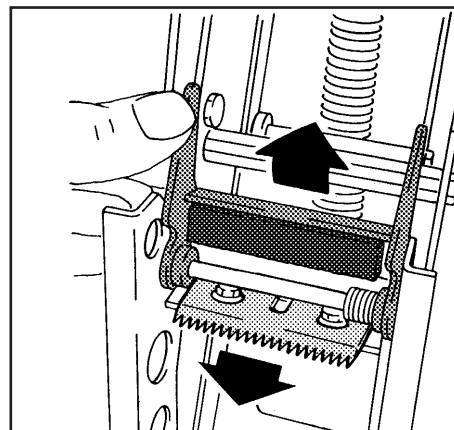

12-MAINTENANCE AND REPAIRS

12.9 BOTTOM DRIVE BELTS REPLACEMENT

Skill operator



Loosen the locking nut of driving pulley (17mm hexagonal wrench) through opening space on cover motorized plan.

Loosen the tensioning screw (with 6mm socket wrench)

Cut the worn belt

Position the new belt and insert the pivot (see the picture)

Adjust the belt tension (see the paragraph 12.11) replace the locking nut.

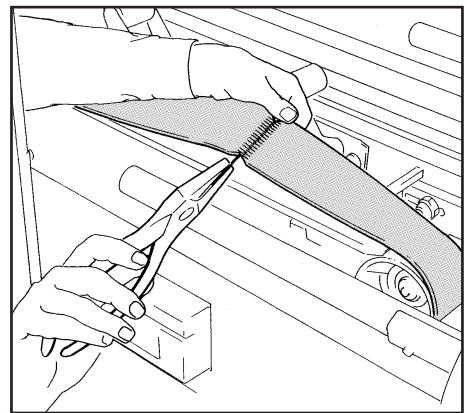
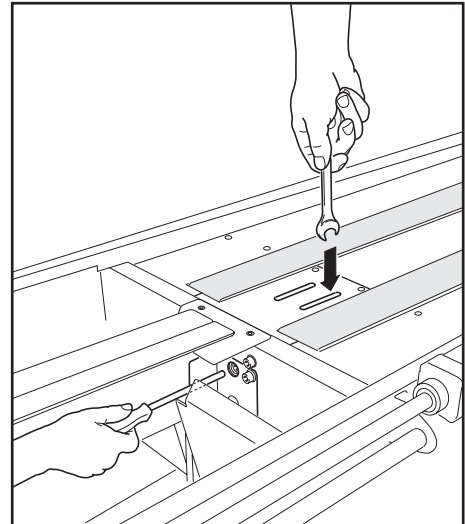

12.10 TOP DRIVE BELTS REPLACEMENT

Loosen the locking nut of driving pulley (17mm hexagonal wrench)

Loosen the tensioning screw (with 6mm socket wrench).

Remove the cover, cut the worn belt, place the belt and insert the pivot (see the picture)

Adjust the belt tension (see the paragraph 12.11) replace the locking nut.

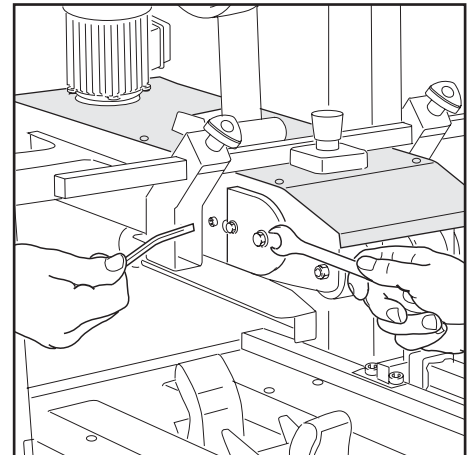

12.11 ADJUSTMENT OF THE BELTS TENSION

Check the tension of the belt by pulling it outwards in the middle.

A force of 3,5 kg should produce a gap of 25 mm (1 inch) between the belt and the frame

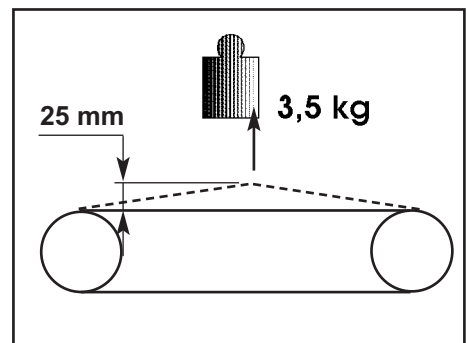

12-MAINTENANCE AND REPAIRS

12.12 COMPRESSED AIR UNIT CONDENSATE DRAIN

Skill operetor



Each time condensation accumulates in the filter, remove it by slightly pressing the button in bottom part of the cup as shown on Picture.

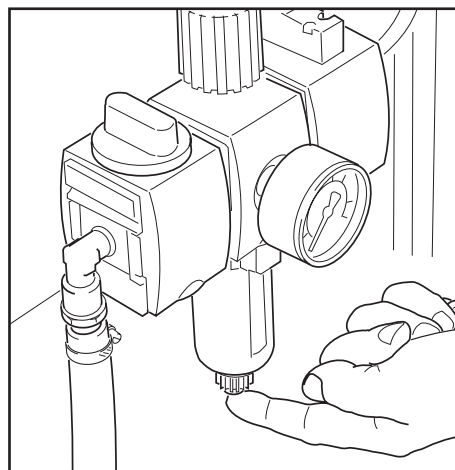

13 -ADDITIONAL INSTRUCTIONS

13.1 INSTRUCTIONS FOR SCRAPPING OF THE MACHINE

In order to dispose of the machine materials please comply with the law in force in your country. Follow the RAEE Directive for the disposal of electric-electronic type components. Please inform the Seller or the Manufacturer of the machine scrapping and return the identification data plate with CE marking.

13.2 NSTRUCTIONS ON EMERGENCY SITUATIONS

In case of danger/fire:
disconnect the electric power.

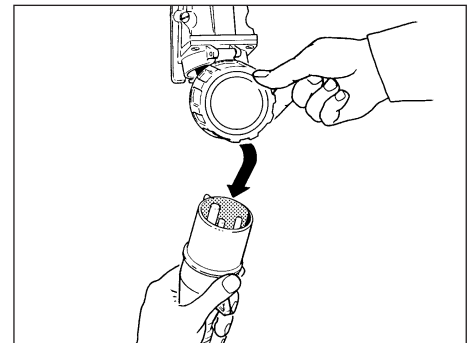

FIRE

In case of fire use an extinguisher containing CO2.

DO NOT use water.

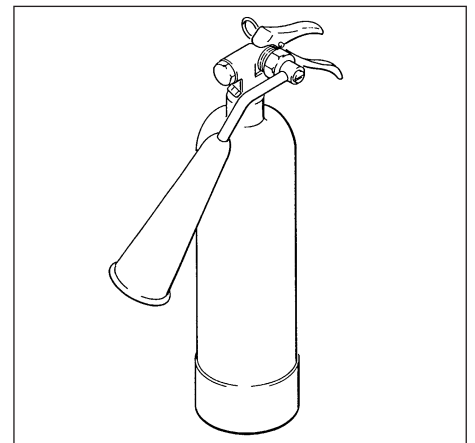

14-ENCLOSURES

13.1 STATEMENT OF CONFORMITY

to the Directives on Machinery 98/37/CE, 2006/95 CE, 89/336 CEE, 108/04 CE, 2002/96/CE, 2003/108/CE.

13.2 SAFETY LABELS

The safety labels are important for the correct use of the machine.

In case any label is damaged or removed, it is responsibility of the user to replace it immediately.

13.3 EMISSIONS OF RADIATIONS, GAS, VAPOURS AND DUST

Nothing to report

13 .4 ELECTRIC TESTS

Electric tests:

1 - Continuity of the ground circuit

2 - Insulation resistance

3 - High voltage insulation

Reference: EN 60204-1 Section 20.2, 20.3, 20.4

15-DRAWING AND DIAGRAMS

ELECTRICAL DIAGRAM (380-415 V 3PH 50/60 Hz)

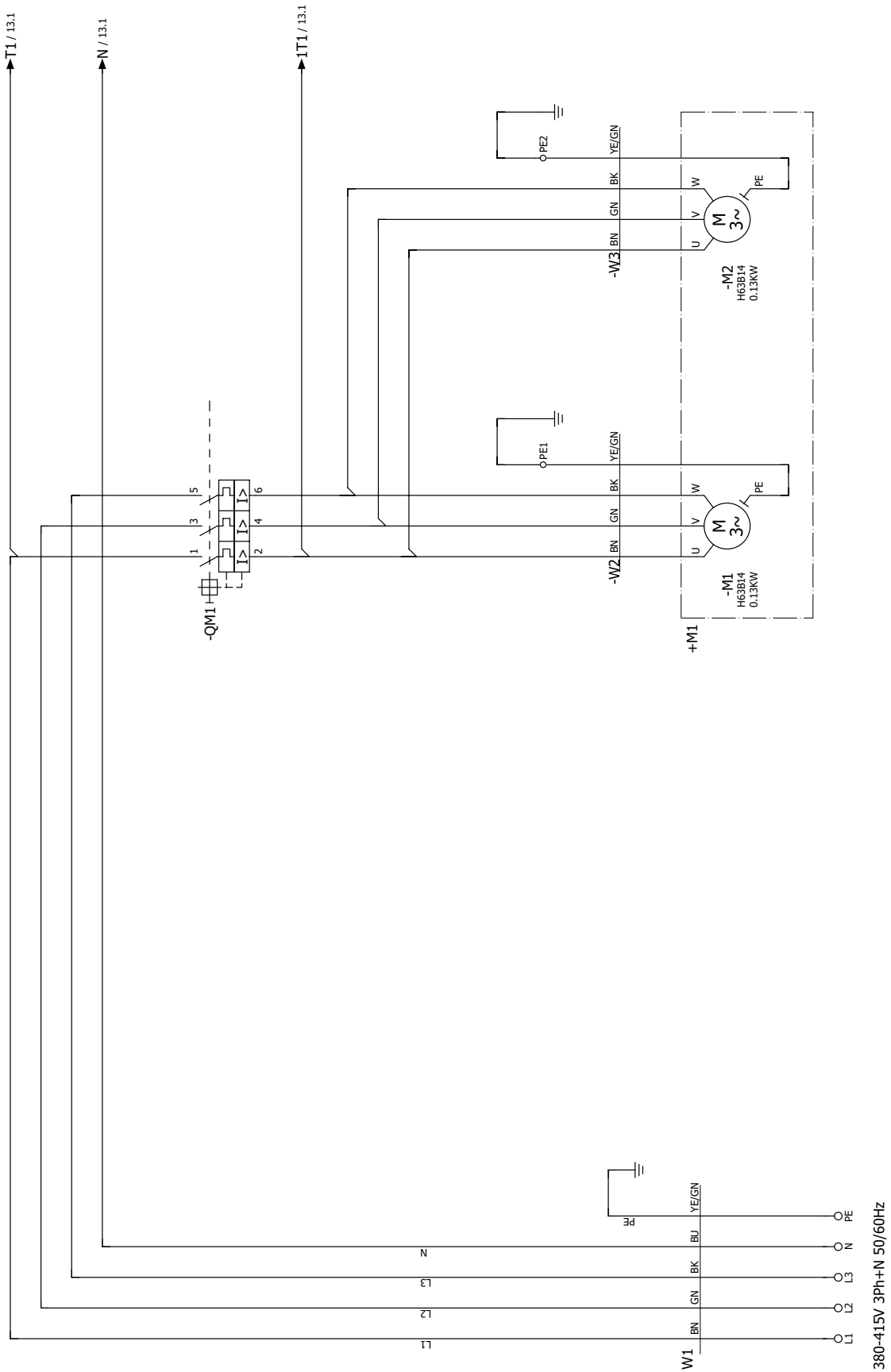

15-DRAWING AND DIAGRAMS

ELECTRICAL DIAGRAM (AUXILIARIES CIRCUIT)

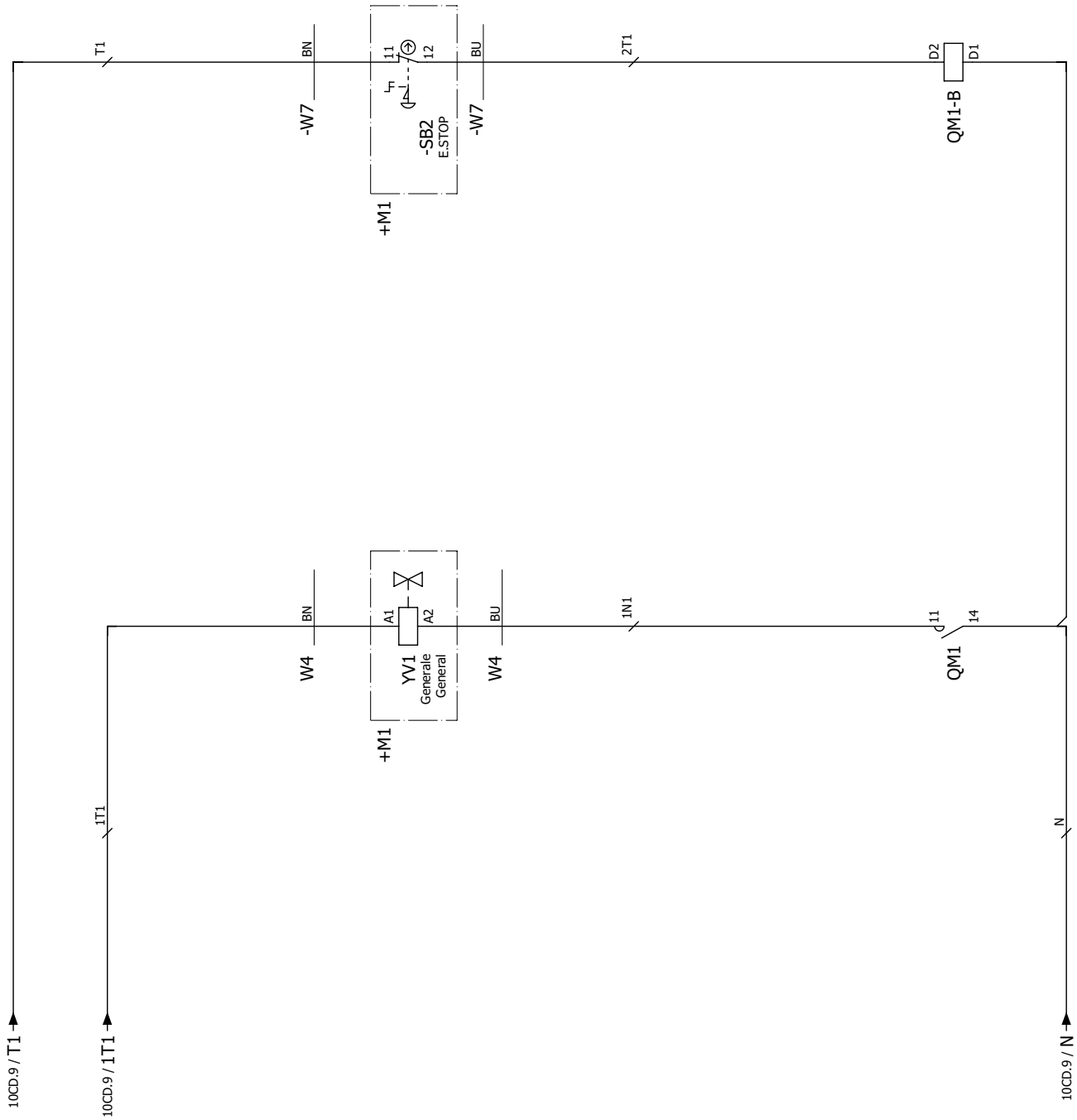

15-DRAWING AND DIAGRAMS

PNEUMATIC SYSTEM

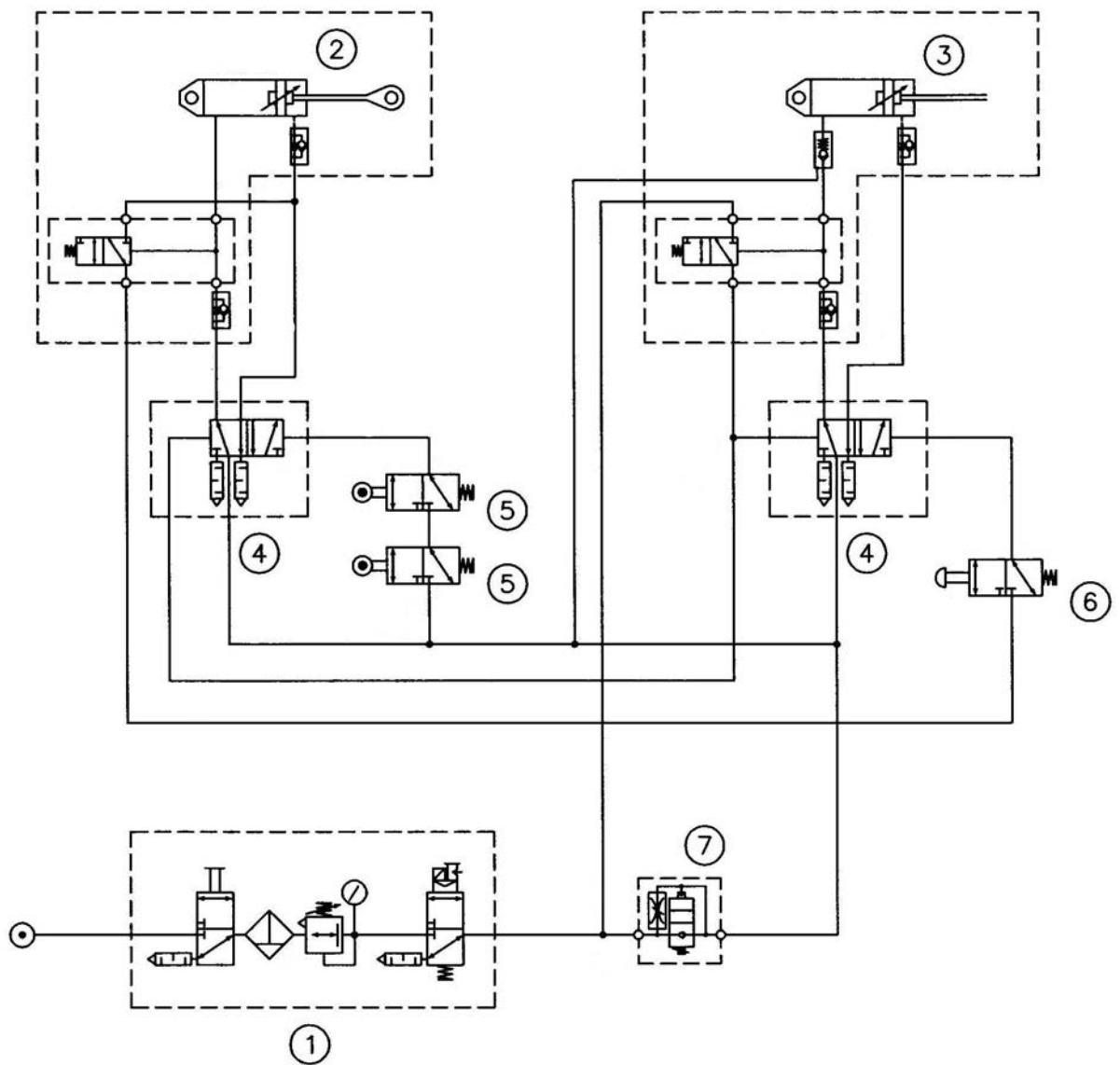

1. Compressed air unit
2. Closing flap cylinder
3. Pusher cylinder
4. 5/2 valve
5. 3/2 valve with roller lever
6. 3/2 valve push button
7. Soft start valve

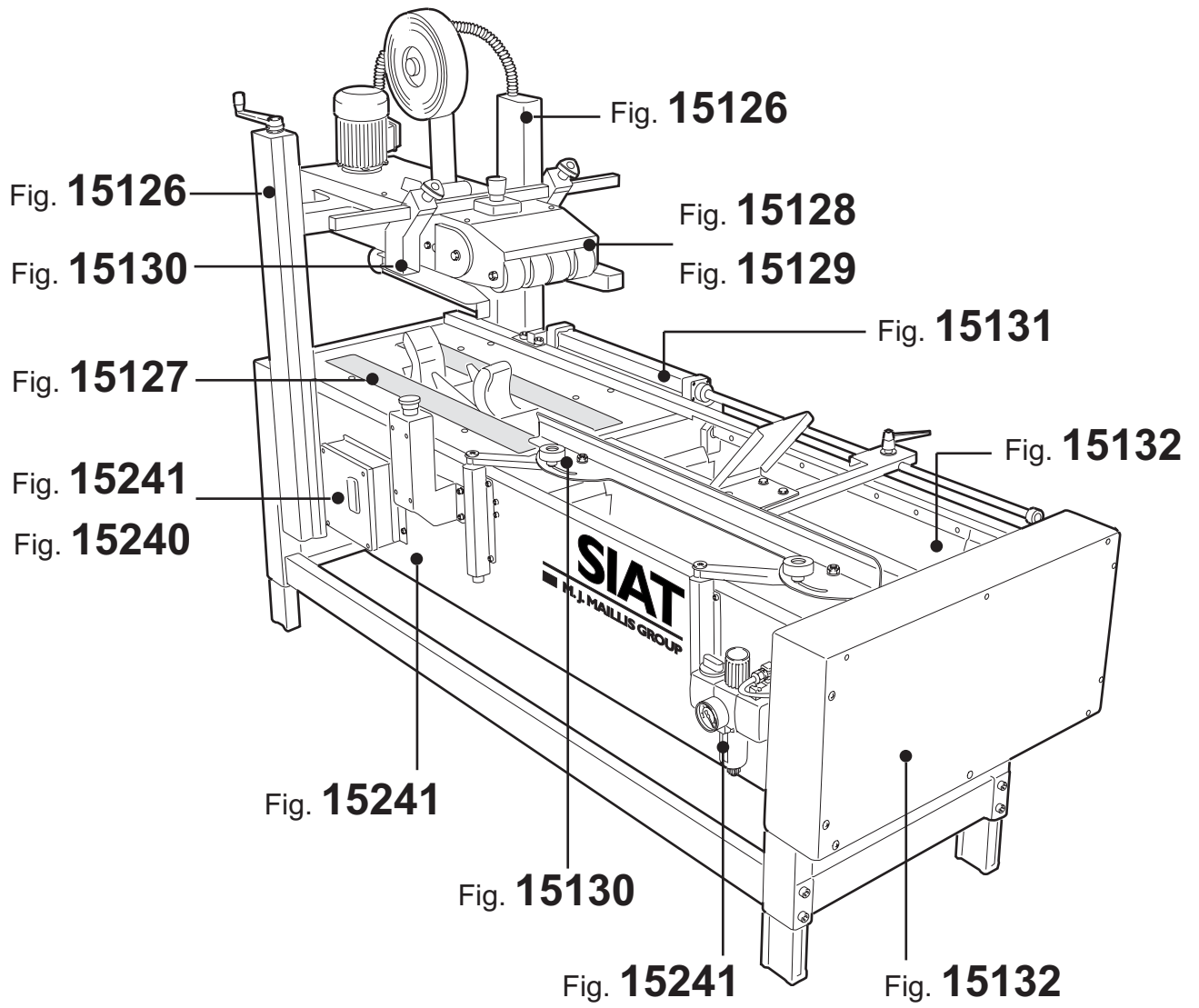

Fig. 15241

BANCALE

SEB0000488

STAZIONE DI CONFEZIONAMENTO

| Pos. | Q.tà | Codice | Descrizione |
|------|------|--------------|------------------------------------------|
| 1 | 1 | SBA0007009 | BANCALE ASS. C/INS. |
| 2 | 4 | SBA0007012 | GAMBA SCORREVOLE C/PIEDINO |
| 3 | 1 | S3510000400A | GAMBA SCORREVOLE (L=250) A20J |
| 4 | 1 | SBC0BC0003 | RIGHELLA MILLIM. GAMBA SCORREVOLE |
| 5 | 1 | S310149805Z | PIEDINO SERIE 2000 NERO |
| 6 | 4 | S4304737ZZZ | GAMBA CON PIEDINO SA2 SR4 |
| 7 | 1 | S350259895A | GAMBA SCORREVOLE L=440 |
| 8 | 1 | S300098295A | RIGHELLA MILLIM. PER GAMBA |
| 9 | 4 | S3401501ZZZ | RUOTA /80 POLIDERNYL |
| 10 | 4 | S320245593Z | DISTANZIALE PER RUOTE SM481 |
| 11 | 4 | S320724493A | ATTACCO RUOTA AS77 |
| 12 | 4 | S340006293Z | RONDELLA PIANA X VITE M12 ZINC. |
| 13 | 4 | S340073593Z | DADO M12 AUTOBLOCCANTE |
| 14 | 8 | S340041592Z | GRANO EIPP M8X8 BR. |
| 15 | 1 | S340004593Z | VITE TE M5X20 ZINCATA |
| 16 | 6 | S340074592Z | RONDELLA DENT. X VITE M5 BRUN. |
| 17 | 2 | S340006193Z | RONDELLA PIANA X VITE M5 ZINC. |
| 18 | 2 | S340002393Z | DADO M5 ZINCATO |
| 19 | 4 | S320567193A | PIASTRINA FISS. GAMBA |
| 20 | 4 | S320589893A | STAFFA PER GAMBE E TRAVERSE SIAT 2000 |
| 21 | 8 | S340058493Z | VITE TCEI M8X16 ZINCATA |
| 22 | 8 | S340012393Z | RONDELLA PIANA X VITE M8 ZINCATA |
| 23 | 2 | SBC0011283V | GUIDA PER TUBI |
| 24 | 1 | SBC0010960V | PIANO LATERALE DX |
| 25 | 1 | SBC0010969V | PIANO LATERALE SX |
| 26 | 1 | SBC0010952V | PIANO SCORRIMENTO CENTRALE |
| 27 | 6 | S340037193Z | VITE TE M5X12 ZINCATA |
| 28 | 6 | S340006193Z | RONDELLA PIANA X VITE M5 ZINC. |
| 29 | 1 | SCB0000363 | GR. COMANDO PNEUMATICO 220V-AC/SR46/PS50 |
| 30 | 1 | SBA0006851 | SUPPORTO TASTO SPINTORE C/INS. |
| 31 | 12 | S340057793Z | VITE TCEI M6X16 ZINCATA |
| 32 | 12 | S340017593Z | RONDELLA PIANA X VITE M6 ZINC. |
| 33 | 1 | SBC0010883V | CHIUSURA SUP. TASTO SPINTORE |
| 34 | 1 | SCB0000555 | VALVOLA 3/2 MAN. M5 ASSEMBL. BOSCH |
| 35 | 32 | S340072093Z | VITE TESTA MEZZA TONDA M5X12 CROCE ZINC. |
| 36 | 1 | SBC0011690V | PIASTRA CHIUSURA FIANCATA |
| 37 | 2 | SBC0010982V | SQUADRA POST. GUIDASCATOLE |
| 38 | 1 | SBC0010983V | SQUADRA SX. ANT. GUIDASCATOLE |
| 39 | 1 | SBC0010984V | SQUADRA DX. ANT. GUIDASCATOLE |
| 40 | 8 | S340012293Z | VITE TCEI M8X20 ZINCATA |
| 41 | 8 | S340012393Z | RONDELLA PIANA X VITE M8 ZINC. |
| 42 | 1 | SBC0010903V | CARTER CASSONETTO |
| 43 | 1 | SBC0010907V | COPERCHIO CASSETTA INTERR. |
| 44 | 1 | SBA0006858 | CASSETTA INTERRUTTORE C/INS. |

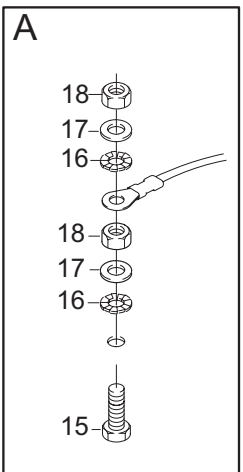
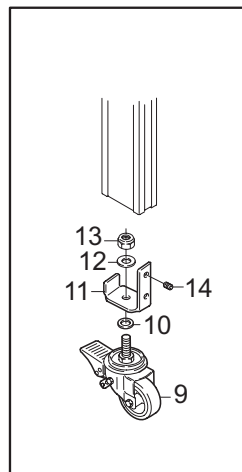
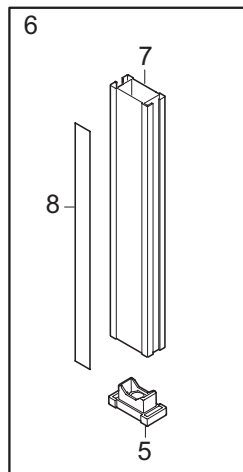
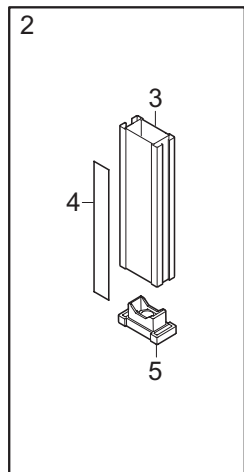
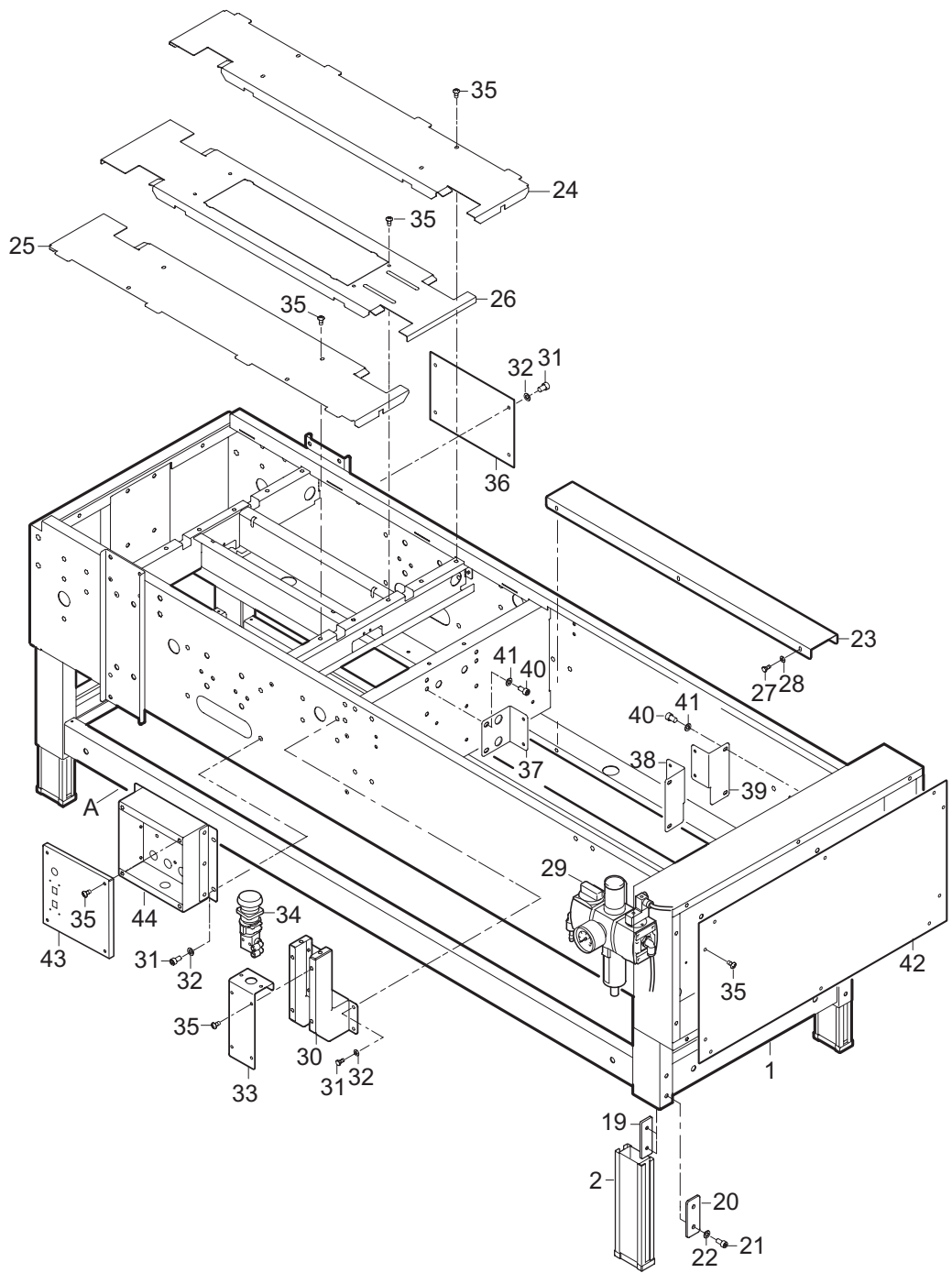

Fig. 15126 COLONNE - CANALINA SEB0000488 STAZIONE DI CONFEZIONAMENTO

| Pos. | Q.tà | Codice | Descrizione |
|------|------|--------------|------------------------------------------|
| 1 | 1 | SBA0006988 | CARRELLO SCORR. C/SUPP. CHIOCC. |
| 2 | 1 | SBA0007070 | CARRELLO SCORREVOLE ASS. |
| 3 | 16 | S3402623ZZZ | CUSCINETTO A SFERE SIAT 2000 |
| 4 | 16 | S330006993Z | VITE CUSCINETTO /33K SP. ZINC. |
| 5 | 16 | S330635893Z | DISTANZIALE D6/12X2 ZINCATO |
| 6 | 16 | S340017593Z | RONDELLA PIANA X VITE M6 ZINC. |
| 7 | 16 | S340000293Z | DADO M6 ZINCATO |
| 8 | 1 | S310157200A | CHIOCCIOLA PER COLONNA S2 |
| 9 | 1 | S370014793Z | MOLLA PER COLONNE 22A ZINC. |
| 10 | 16 | S340028093Z | VITE TE M8X20 ZINCATA |
| 11 | 16 | S340012393Z | RONDELLA PIANA X VITE M8 ZINC. |
| 12 | 8 | S340136592Z | GRANO EIPC M8X10 BR. |
| 13 | 2 | SBC0011458V | COLONNA FISSA |
| 14 | 4 | SBC0011695T | PIASTRINA FISSAGGIO COLONNA |
| 15 | 1 | S331634093A | VITE SOLLEVAMENTO PER S2 CON AS82 |
| 16 | 1 | S331579293A | BUSSOLA PER VITE SOLLEVAMENTO S2 |
| 17 | 1 | S340102292Z | SPINA ELASTICA D4X30 BRUNITA |
| 18 | 1 | S321192061A | TESTATA C/FORO COLONNA FISSA S8 CE |
| 19 | 4 | S340344893Z | TVITE TBEI UNI 7380 M8X16 |
| 20 | 1 | S3100583ZZZ | BUSSOLA |
| 21 | 1 | S331579193A | GHIERA X VITE SOLLEVAMENTO S2 |
| 22 | 1 | S340014293Z | VITE TCEI M4X25 ZINCATA |
| 23 | 1 | S3402700ZZZ | MANOV. 'ELESA' MT. 80 AS 10X10 SIAT 2000 |
| 24 | 1 | S350050693Z | RONDELLA FISSAGGIO MOTORI |
| 25 | 1 | S340051693Z | VITE TSVEI M5X12 ZINCATA |
| 26 | 1 | S321191847A | TESTATA COLONNA FISSA 52A 3M |
| 27 | 1 | S45100001M8A | CANALINA CAVI ELETTRICI C/INS. (A20) |
| 28 | 1 | S370023247Z | MOLLA BANDELLA |
| 29 | 2 | S340057793Z | VITE TCEI M6X16 ZINCATA |
| 30 | 2 | S340017593Z | RONDELLA PIANA X VITE M6 ZINCATA |
| 31 | 1 | S32100019M8A | CARTER CANALINA VERN. (A20) |
| 32 | 4 | S340031893Z | VITE TCEI M5X12 ZINCATA |
| 33 | 8 | S340006193Z | RONDELLA PIANA X VITE M5 ZINC. |
| 34 | 4 | S340072093Z | VITE TESTA MEZZA TONDA M5X12 CROCE |
| 35 | 1 | S3801216ZZZ | PASSACAVO GOMMA X FORO /16,5 |

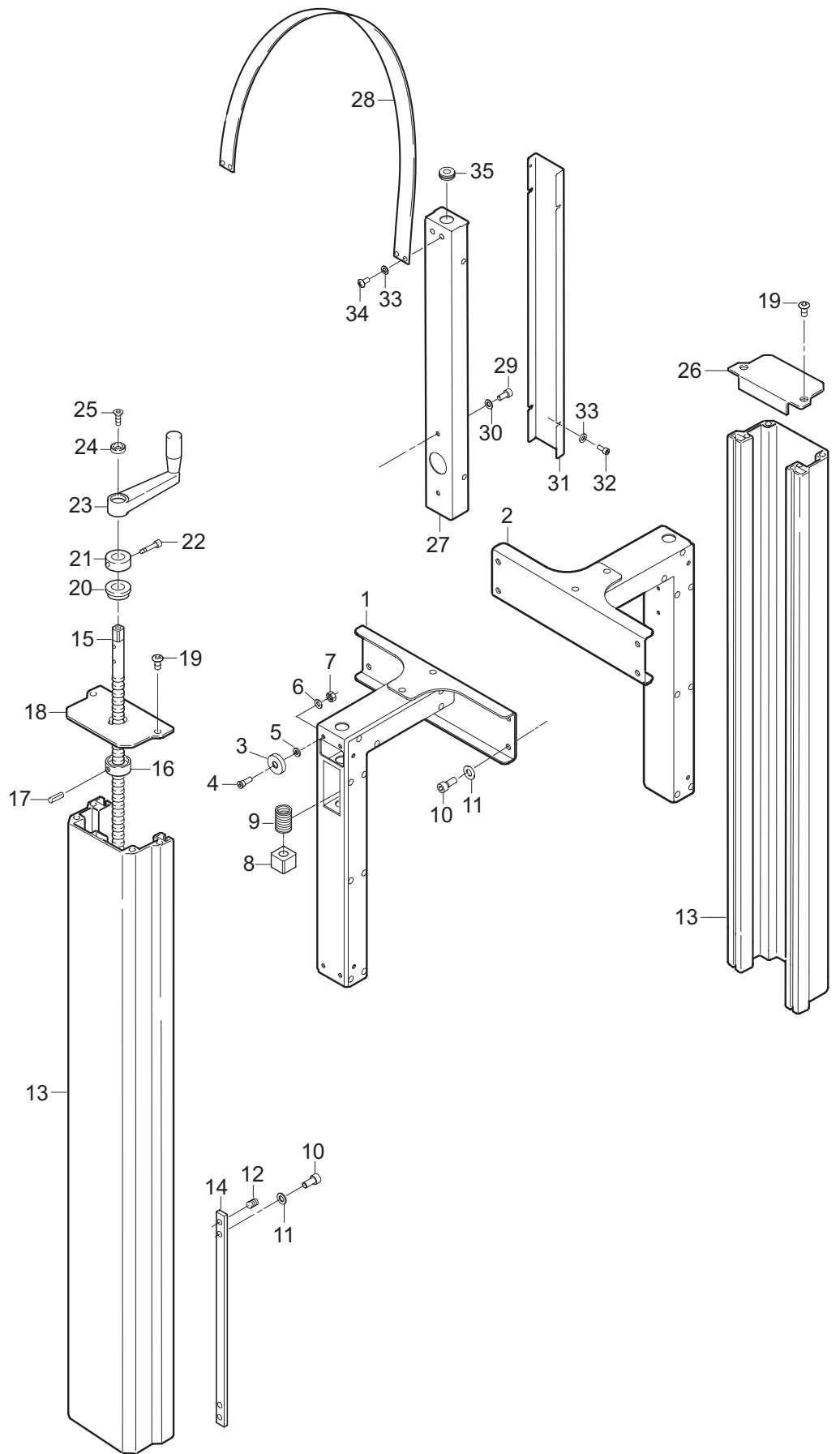

Fig. 15127 MOTORIZZAZIONE INFERIORE SEB0000488 STAZIONE DI CONFEZIONAMENTO

| Pos. | Q.tà | Codice | Descrizione |
|-------------|-------------|---------------|---------------------------------------------|
| 1 | 1 | S3803440ZZZ | MOT. H63 A4 B5 220/240 V - 380/415 V 50 HZ |
| 1 | 1 | S3803449ZZZ | MOT. MH63 C4 B5 220/240 V MF 50 HZ 0,13 KW |
| 1 | 1 | S3803442ZZZ | MOT. H63 A4 B5 KW 0,13 200 V 50/60 HZ 220 V |
| 1 | 1 | S3801993ZZZ | MOTORE 220/240 V 60 HZ MH63 C4-B5 KW 0,12 |
| 1 | 1 | S3800454ZZZ | MOT. H63 A4 B5 260 V-440 V 50 HZ 3F 0,13 KW |
| 2 | 1 | S3803594ZZZ | RIDUTT. NMRS041 1:20 ALBERO CORTO SM |
| 3 | 1 | SBA0007015 | STAFFA DX RIDUTTORE INF. C/INS. |
| 4 | 1 | SBA0007016 | STAFFA SX RIDUTTORE INF. C/INS. |
| 5 | 8 | S340032993Z | VITE TE M5X16 ZINCATA |
| 6 | 8 | S340006193Z | RONDELLA PIANA X VITE M5 ZINC. |
| 7 | 2 | S4705876ZZZ | PULEGGIA MOTRICE ASS. C/ANELLI |
| 8 | 4 | S310054048Z | ANELLO PER PULEGGIA |
| 9 | 2 | S331606293A | DISTANZIALE PER PULEGGE MOTRICI SA2 SR4 |
| 10 | 2 | S350051593Z | DADO SPEC. AUTOBLOCC. M20X1 ZINC. |
| 11 | 1 | S4510001005A | TENDITORE C/INSERTI |
| 12 | 1 | S3210001705A | CARRELLO SCORR. TENDITORE (A20/A70/R70) |
| 13 | 2 | S4601730ZZZ | PULEGGIA FOLLE COMPL. |
| 14 | 2 | S3310000292A | PERNO PER PULEGGIA FOLLE (A20/A70/R70) |
| 15 | 2 | S3310000493A | DADO SPEC. M25X1,5 (A20/A70/R70) |
| 16 | 2 | S3210004793A | RONDELLA 38X1,5X25,5 (A20/A70/R70) |
| 17 | 2 | S350180293Z | DIST. PERNO MOT. INF. 200A-700A-700R 3M |
| 18 | 2 | S340021993Z | RONDELLA PIANA X VITE M10 ZINC. |
| 19 | 2 | S340043893Z | DADO AUTOBLOCCANTE M10 BASSO |
| 20 | 2 | S330491693Z | RONDELLA /6,5/30X5 |
| 21 | 2 | S340002492Z | RONDELLA ELASTICA X VITE M6 |
| 22 | 2 | S340057793Z | VITE TCEI M6X16 ZINCATA |
| 23 | 2 | S340299793Z | VITE TCEI M8X100 ZINCATA 120af |
| 24 | 10 | S340012293Z | VITE TCEI M8X20 ZINCATA |
| 25 | 10 | S340012393Z | RONDELLA PIANA X VITE M8 ZINC. |
| 26 | 2 | S3402232ZZZ | CING. TRASCINAM. H=75X1712 +-2,5 C/GIUNZ. |

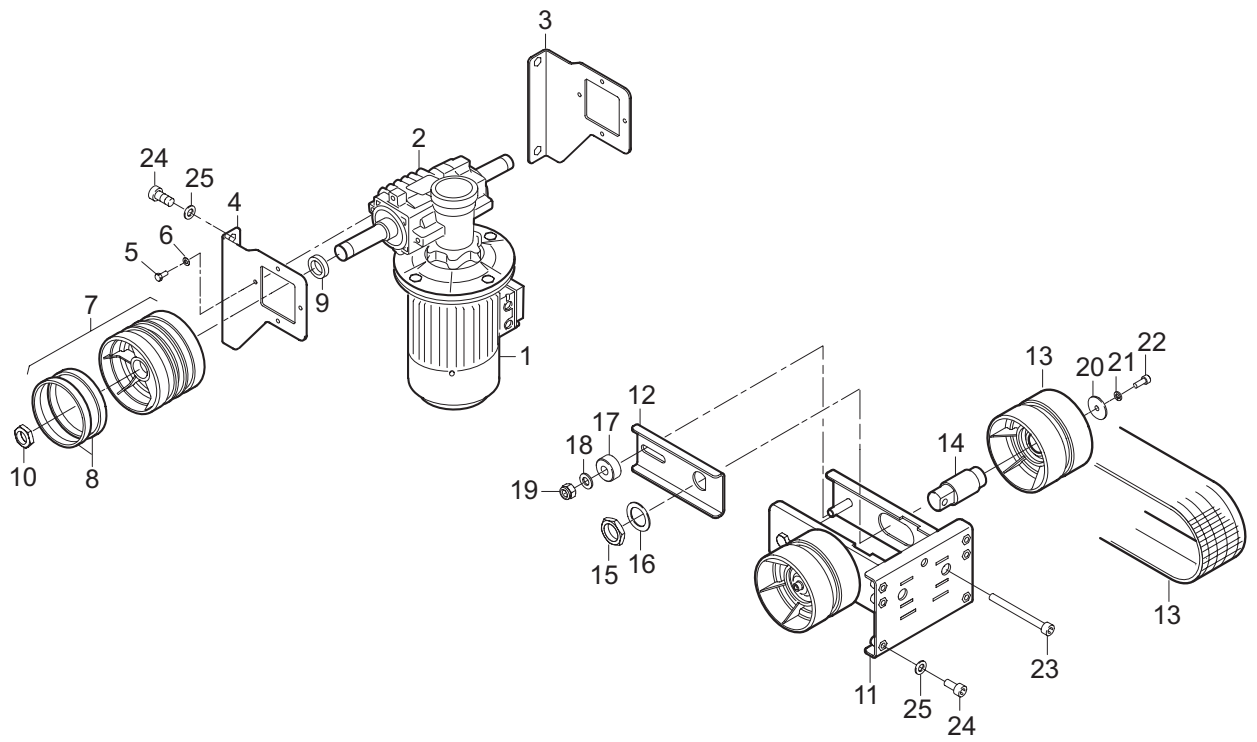

Fig. 15128 MOTORIZZAZIONE SUPERIORE SEB0000488 STAZIONE DI CONFEZIONAMENTO

| Pos. | Q.tà | Codice | Descrizione |
|-------------|-------------|---------------|---------------------------------------------|
| 1 | 1 | SCC0001637 | MOT. H63-B14 A5 200 V 50 HZ 200/220 V 60 HZ |
| 1 | 1 | S3805242ZZZ | MOT. H63-B14 220/415 V 50 HZ 440 V 60 HZ 3F |
| 1 | 1 | SCC0001626 | MOT. H63-B14 A5 440 V 50 HZ 3F 0,13 KW |
| 1 | 1 | SCC0001645 | MOT. H63-B14 A5 220/240 V 50 HZ MF 0,13 KW |
| 1 | 1 | SCC0001646 | MOT. H63-B14 220/240 V 60 HZ MF |
| 2 | 1 | SCA0000990 | RIDUTTORE CHM-40 20 63B14U CHIARAVALLI |
| 3 | 1 | SBA0007060 | SPALLA EST. DX MOTORIZZ. C/INS. |
| 4 | 1 | SBA0007061 | SPALLA EST. SX MOTORIZZ. C/INS. |
| 5 | 1 | SBA0007057 | SPALLA DX MOTORIZZ. SUP. C/INS. |
| 6 | 1 | SBA0007058 | SPALLA SX MOTORIZZ. SUP. C/INS. |
| 7 | 1 | SBC0011108V | SCIVOLO INFERIORE MOTORIZZ. |
| 8 | 1 | SBA0007059 | SUPPORTO TASTO EMERGENZA C/INS. |
| 9 | 8 | S340011293Z | VITE TCEI M5X16 ZINCATA |
| 10 | 8 | S340006193Z | RONDELLA PIANA X VITE M5 ZINC. |
| 11 | 8 | SBC0011102T | PERNO FISSAGGIO RIDUTTORE |
| 12 | 2 | SBC0011105T | ALBERO RIDUTTORE SUPERIORE |
| 13 | 1 | SBC0011106T | PERNO CENTRALE RIDUTTORE SUP. |
| 14 | 2 | S4705877ZZZ | PULEGGIA MOTRICE BASSA CON ANELLI X SM |
| 15 | 4 | S310054048Z | ANELLO PER PULEGGIA |
| 16 | 2 | S340004893Z | VITE TSVEI M8X16 ZINCATA |
| 17 | 2 | S331823893A | RONDELLA /8 SP. 4 MM HS |
| 18 | 2 | S3400183ZZZ | LINGUETTA 5X5X30 |
| 19 | 2 | S3400641ZZZ | LINGUETTA 6X6X25 |
| 20 | 2 | S440841393A | ALBERO CON CAMMA DI REGOL. ASS. S8-CE |
| 21 | 2 | S332577493A | PERNO PER RULLINO DI REGOLAZIONE S8-CE |
| 22 | 4 | S340006792Z | ANELLO ELASTICO X ALBERO D. 15 |
| 23 | 2 | SBC0011099 | CARRELLO TENDICINGHIA EST. |
| 24 | 2 | SBA0006970 | CARRELLO TENDICINGHIA SUP. ASS. |
| 25 | 2 | S471403200B | PULEGGIA FOLLE PREMONT. S8-CE |
| 26 | 2 | S4602652ZZZ | PULEGGIA FOLLE SM8 RIBASSATA |
| 27 | 2 | S332570392A | ALBERO PER PULEGGIA FOLLE S8-CE |
| 28 | 2 | S340010492Z | ANELLO ARRESTO X ALBERO /25 BR |
| 29 | 2 | S3403005ZZZ | CING. DI TRASCINAMENTO C/GIUNZ. H=55 L=1510 |
| 30 | 1 | SBC0011455T | PERNO RULLI ENTRATA |
| 31 | 2 | SBC0011454T | TUBETTO RULLI ENTRATA |
| 32 | 4 | S310058005Z | RULLO ENTRATA |
| 33 | 1 | S3101013ZZZ | DISTANZIALE X RULLI ENTRATA 700a/3M |
| 34 | 4 | SBC0004015 | DISTANZIALE RULLI ENTRATA |
| 35 | 2 | S340033193Z | DADO CIECO M8 C/CALOTTA NYLON NERO |
| 36 | 1 | S331636693A | TUBO /15 LG.106 RUL. ENTRATA 700a/700r/3M |
| 37 | 1 | SBC0011103V | CARTER ANTERIORE MOTORIZZ. |
| 38 | 1 | SBC0011107 | CARTER POSTERIORE MOTORIZZ. |
| 39 | 1 | SBC0011100 | CARTER SUPERIORE MOTORIZZ. |
| 40 | 10 | S340072093Z | VITE TESTA MEZZA TONDA M5X12 CROCE ZINC. |
| 41 | 2 | S310223600A | RULLINO PER REGOLAZIONE TENSIONE |
| 42 | 2 | S340407993A | VITE TE M10X85 |
| 43 | 2 | S340021993Z | RONDELLA PIANA X VITE M10 ZINC. |
| 44 | 18 | S340002193Z | VITE TE M6X12 |
| 45 | 18 | S340017595Z | RONDELLA PIANA X VITE M6 |
| 46 | 2 | S340012393Z | RONDELLA PIANA X VITE M8 |
| 47 | 1 | S3805196ZZZ | SCATOLA GIALLA 3SB3801-0AC |
| 48 | 1 | S3805197ZZZ | CONTATTO NC 3SB3420-0C |
| 49 | 1 | S3805198ZZZ | PULSANTE EMERGENZA 3SB3000-1HA20 |

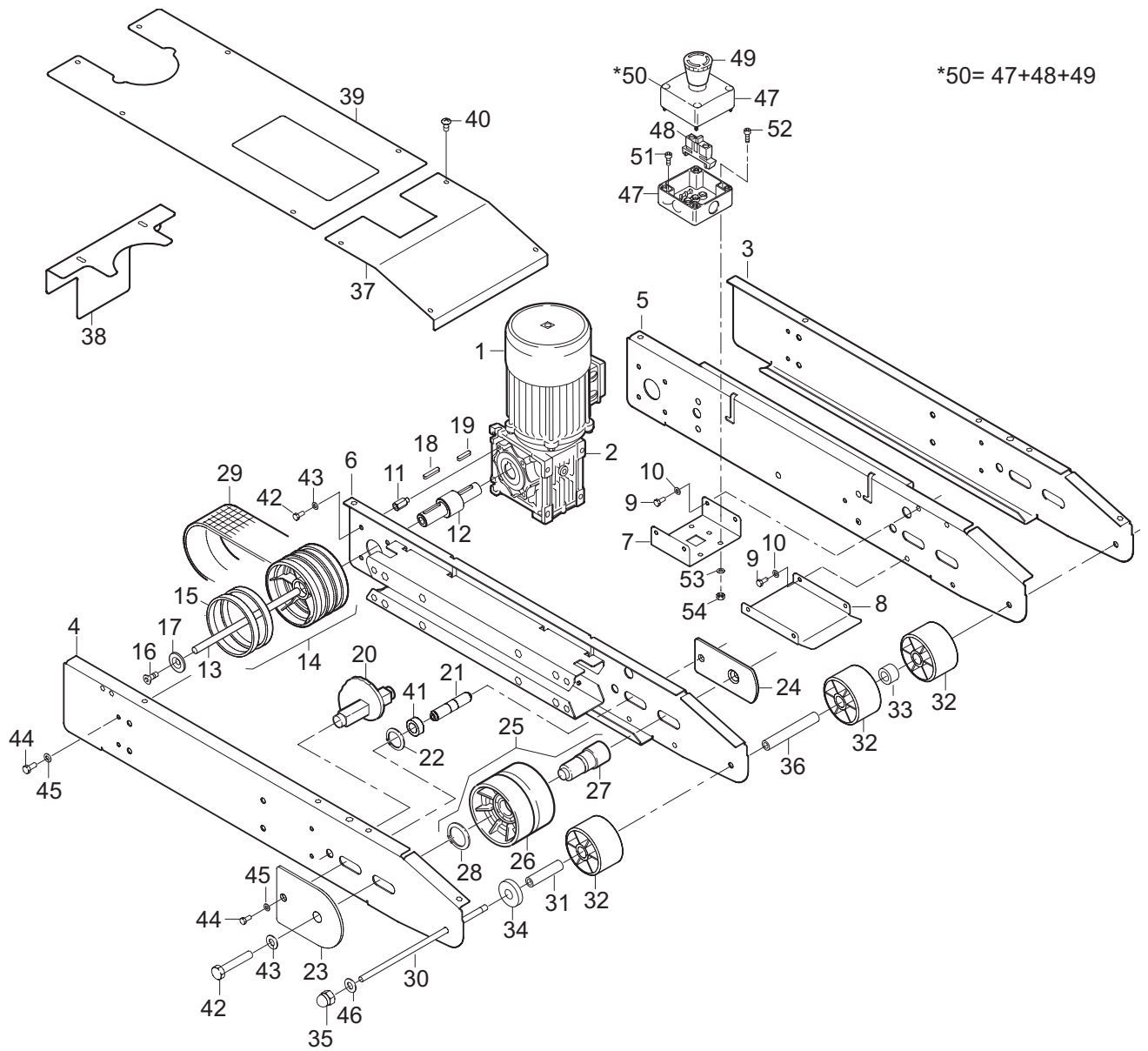

Fig. 15128 MOTORIZZAZIONE SUPERIORE SEB0000488 STAZIONE DI CONFEZIONAMENTO

| Pos. | Q.tà | Codice | Descrizione |
|-------------|-------------|---------------|-----------------------------------------|
| 49 | 1 | S3805198ZZZ | PULSANTE EMERGENZA 3SB3000-1HA20 |
| 50 | 1 | S471168900A | PULSANTE EMERGENZA ASS. SM/XL 'SIEMENS' |
| 51 | 1 | S340025593Z | VITE TCEI M4X10 ZINCATA |
| 52 | 1 | S340042093Z | VITE TCEI M4X16 |
| 53 | 1 | S340183093Z | RONDELLA DENT. X VITE M4 |
| 54 | 1 | S340000193Z | DADO M4 ZINCATO |

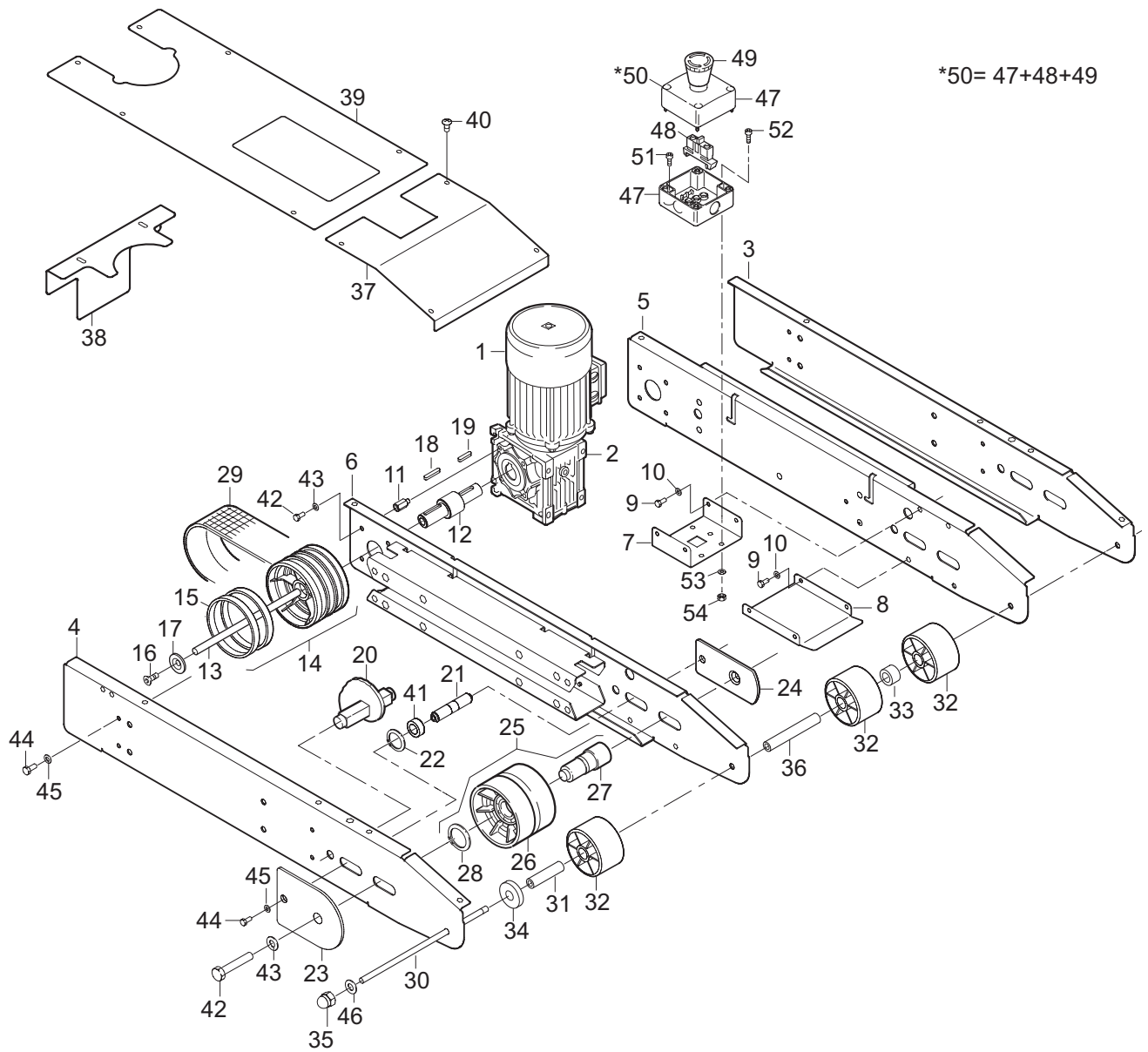
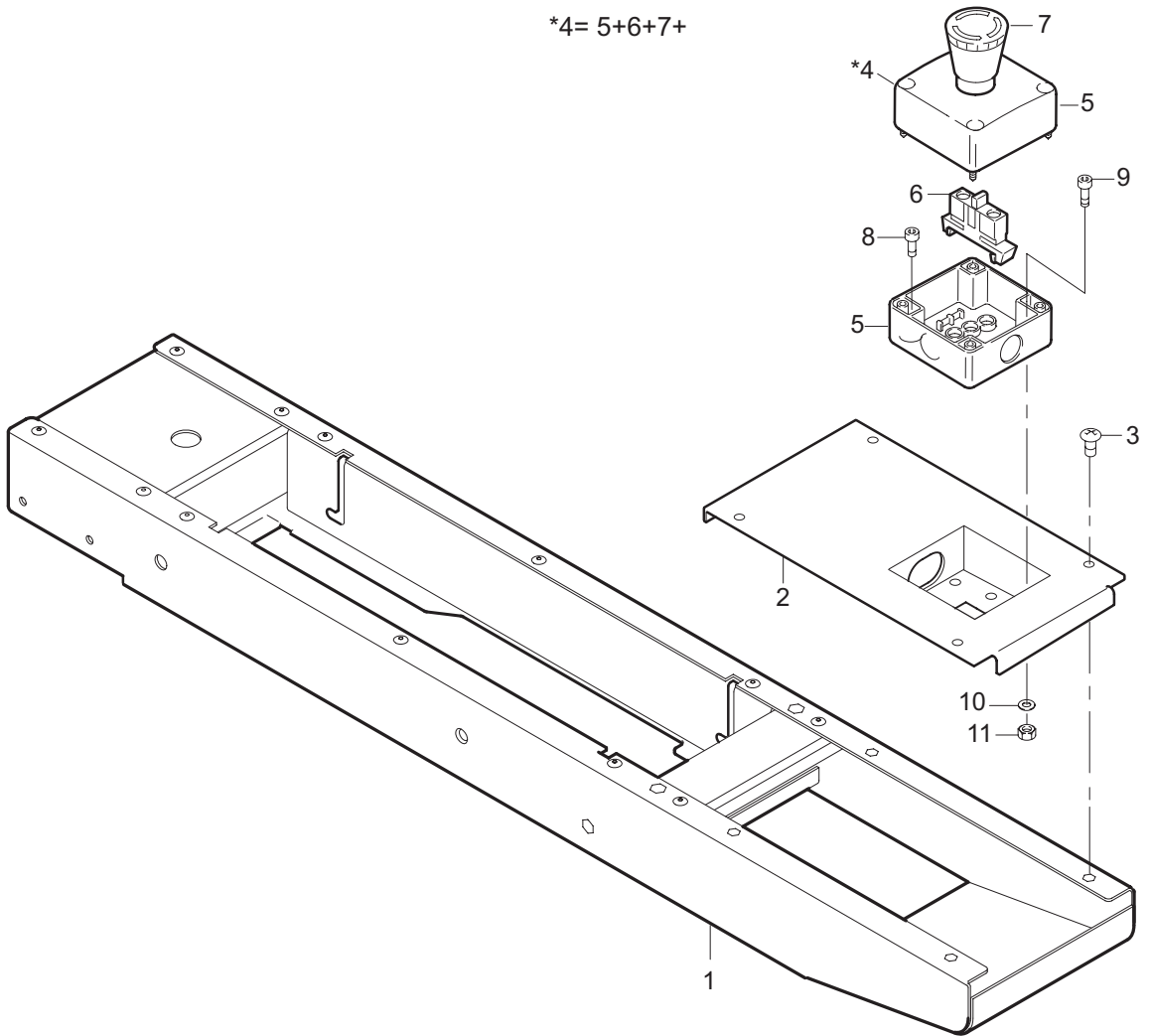

Fig. 15129 TESTATA SUPERIORE SEB0000488 STAZIONE DI CONFEZIONAMENTO

| Pos. | Q.tà | Codice | Descrizione |
|-------------|-------------|---------------|-----------------------------------------|
| 1 | 1 | SBA0007097 | TESTATA SUPERIORE C./INS. |
| 2 | 1 | SBA0007100V | CARTER TASTO A FUNGO ASS. |
| 3 | 4 | S340170893Z | VITE TESTA MEZZA TONDA M5X16 |
| 4 | 1 | S471168900A | PULSANTE EMERGENZA ASS. SM/XL 'SIEMENS' |
| 5 | 1 | S3805196ZZZ | SCATOLA GIALLA 3SB3801-0AC |
| 6 | 1 | S3805197ZZZ | CONTATTO NC 3SB3420-0C |
| 7 | 1 | S3805198ZZZ | PULSANTE EMERG. 3SB3000-1HA20 |
| 8 | 1 | S340025593Z | VITE TCEI M4X10 ZINCATA |
| 9 | 1 | S340042093Z | VITE TCEI M4X16 |
| 10 | 1 | S340183093Z | RONDELLA DENT. X VITE M4 |
| 11 | 1 | S340000193Z | DADO M4 ZINCATO |

*4= 5+6+7+



| Pos. | Q.tà | Codice | Descrizione |
|------|------|--------------|-----------------------------------------|
| 1 | 1 | SBC0011111T | TUBO PRESSATORI LATERALI |
| 2 | 2 | S340036793Z | VITE TCEI M6X35 ZINCATA |
| 3 | 2 | S340003393Z | RONDELLA TRIPLA X VITE M6 ZINCATA |
| 4 | 1 | SBA0007063 | GUIDA LATERALE DX C/INS. |
| 5 | 1 | SBA0007064 | GUIDA LATERALE SX C/INS. |
| 6 | 2 | S3410000400A | MANOPOLA VTR. 50 P-M10X30 (ELESA) |
| 7 | 2 | S340084705Z | TAPPO /25X25 |
| 8 | 2 | SBA006897V | SUPPORTO LEVE ASS. |
| 9 | 2 | SBC0010975T | PERNO SUPPORTO LEVE |
| 10 | 4 | SBC0010977 | BUSSOLA SUPPORTO LEVE |
| 11 | 2 | SBA0006892V | LEVA GUIDA LATERALE ASS. |
| 12 | 2 | SBC0010979T | RONDELLA PERNO SUPP. LEVE |
| 13 | 12 | S340057793Z | VITE TCEI M6X16 ZINCATA |
| 14 | 2 | S340003393Z | RONDELAL TRIPLA X VITE M6 ZINC. |
| 15 | 8 | S340017593Z | RONDELAL PIANA X VITE M6 ZINC. |
| 16 | 1 | SBC0010966V | GUIDA LATERALE |
| 17 | 8 | S340021993Z | RONDELLA PIANA X VITE M10 ZINC. |
| 18 | 8 | S3100079ZZZ | RONDELLA NYLON /10,5/18X1 |
| 19 | 4 | S3401681ZZZ | MANOPOLA 'ELESA' VTR-B-M10 200A-700A 3M |
| 20 | 4 | S340028393Z | DADO AUTOBLOCCANTE M8 BASSO ZINCATO |
| 21 | 8 | S340012393Z | RONDELLA PIANA X VITE M8 ZINCATA |

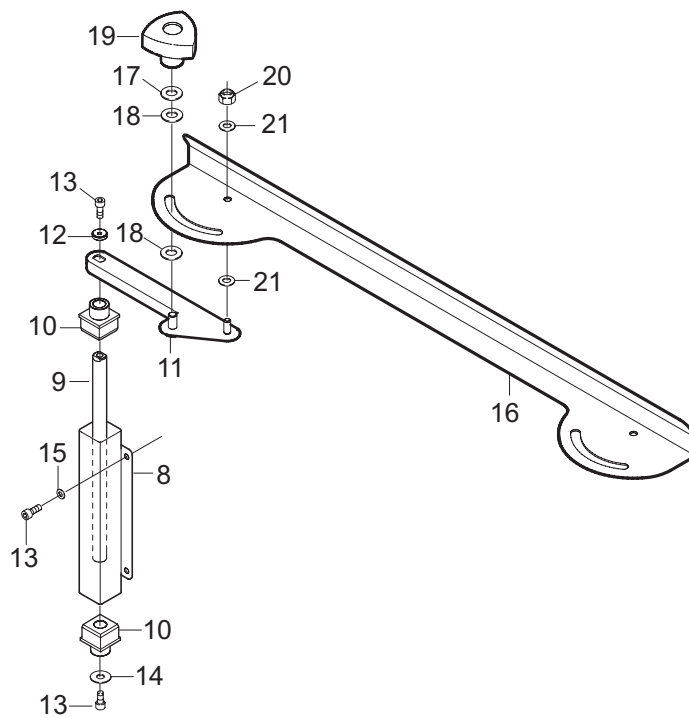
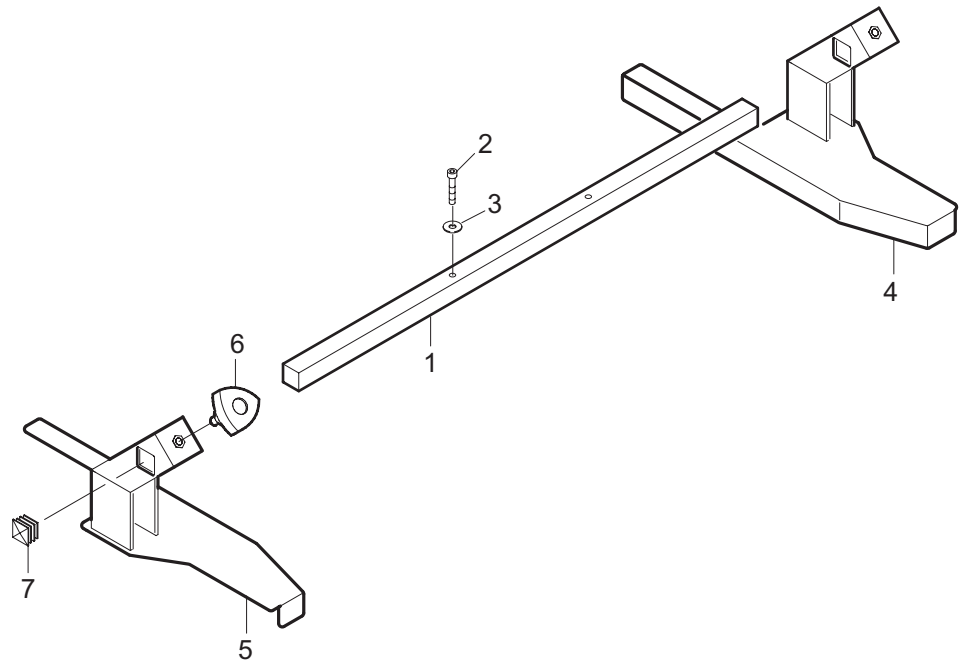

| Pos. | Q.tà | Codice | Descrizione |
|------|------|-------------|------------------------------------------|
| 1 | 1 | SBA0006954T | SUPPORTO CILINDRO SPINTORE |
| 2 | 2 | S340058493Z | VITE TCEI M8X16 ZINCATA |
| 3 | 2 | S340012393Z | RONDELLA PIANA X VITE M8 ZINC. |
| 4 | 1 | SCB0000547 | CILINDRO D.40X400 BOSCH ASSEMBL. |
| 5 | 1 | SCB0000501 | CILINDRO ISO PROFILO PRA 40X400 BOSCH |
| 6 | 1 | SCB0000345 | CERNIERA POST. FEMMINA MP2-D.40 |
| 7 | 2 | SCB0000356 | REGOLATORE DI FLUSSO UNID. 1/4" - 8 |
| 8 | 1 | SCB0000546 | ELEMENTO NOT G1/4 TUBO D.4 BOSCH |
| 9 | 1 | SCB0000563 | VALVOLA ANTIRITORNO PILOTATA G1/4 BOSCH |
| 10 | 1 | S3801393ZZZ | RACCORDO DIRITTO 31010813 CF13 |
| 11 | 1 | S340013592Z | ANELLO ARRESTO X ALBERO BR. |
| 12 | 1 | SBC0011064 | PROLUNGA ASTA SPINTORE |
| 13 | 2 | S332407093A | ANELLO DI FERMO 130CF-3M |
| 14 | 2 | S340038892Z | GRANI EIPP M5X6 BR. |
| 15 | 1 | S332406623A | GUIDA BLOCCAGGIO SPINTORE |
| 16 | 1 | S332406592A | PERNO BLOCCAGGIO SPINTORE |
| 17 | 1 | SBC0011057 | ASTA GUIDA SPINTORE |
| 18 | 1 | SBC0011070V | SQUADRA SOSTEGNO ASTA |
| 19 | 6 | S340002693Z | VITE TE M6X16 ZINCATA |
| 20 | 6 | S340017593Z | RONDELLA PIANA X VITE M6 ZINC. |
| 21 | 2 | S340028093Z | VITE TE M8X20 ZINCATA |
| 22 | 2 | S340012393Z | RONDELLA PIANA X VITE M8 ZINC. |
| 23 | 1 | S4305085ZZZ | BLOC. SCORR. SPINTORE C/BUSSOLE 130CF-3M |
| 24 | 2 | S340553147A | SQUAD. FIX. SPINTORE C/INS. 130CF-3M |
| 25 | 10 | S340057793Z | VITE TCEI M6X16 ZINCATA |
| 26 | 10 | S340017593Z | RONDELLA PIANA X VITE M6 ZINC. |
| 27 | 1 | S3402527ZZZ | MANIGLIA A RIPRESA 'ELESA' MR.80 A=M8 |
| 28 | 1 | S340065593Z | RONDELLA TRIPLA X VITE M8 ZINC. |
| 29 | 1 | SBA0007055 | BRACCIO SPINTORE C/INS. |
| 30 | 1 | SBC0011052 | CHIUDIFALDA POSTERIORE |
| 31 | 1 | SBC9911985 | GUIDA ANTERIORE SPINTORE |
| 32 | 2 | S340002793Z | VITE TSVEI M6X12 ZINCATA |

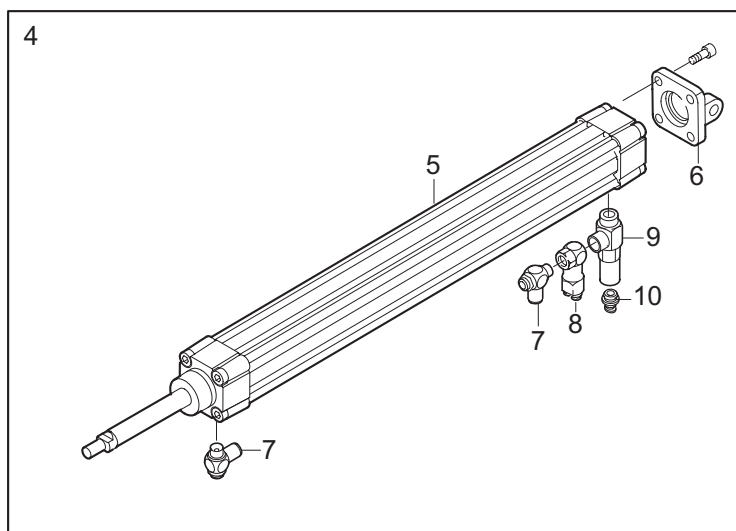
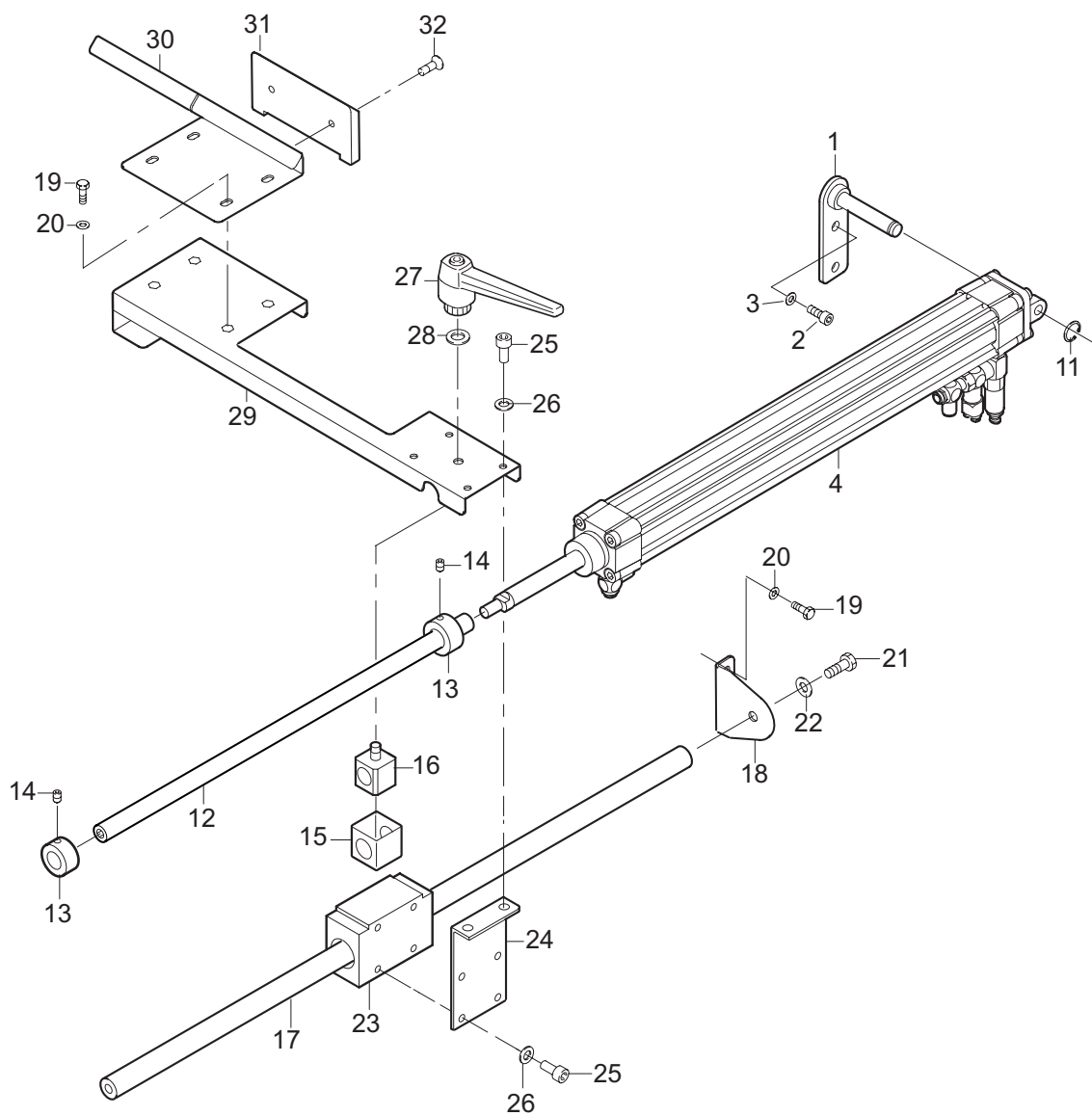

| Pos. | Q.tà | Codice | Descrizione |
|------|------|-------------|---------------------------------------|
| 1 | 2 | SCA0000984 | SUPPORTO A FLANGIA LEGGERA SBLF 004 |
| 2 | 4 | S340012293Z | VITE TCEI M8X20 ZINCATA |
| 3 | 4 | S340012393Z | RONDELLA PIANA X VITE M8 ZINC. |
| 4 | 2 | SBC0011013T | PIGNONE PERNO CHIUDIFALDA |
| 5 | 1 | SBC0011019V | BIELLA PER CHIUDIFALDE |
| 6 | 3 | S340002693Z | VITE TE M6X16 ZINCATA |
| 7 | 3 | S340017593Z | RONDELLA PIANA X VITE M6 ZINC. |
| 8 | 2 | S331823893A | RONDELLA /8 SP. 4 MM HS |
| 9 | 2 | S340004893Z | VITE TSVEI M8X16 ZINCATA |
| 10 | 1 | SBC0011020T | PERNO CILINDRO CHIUDIFALDE |
| 11 | 1 | S330733793Z | RONDELLA /10,5 - 30X5 |
| 12 | 1 | S340036693Z | DADO M10 BASSO ZINCATO |
| 13 | 1 | SCB0000550 | CILINDRO PRA D.50X125 ASSEMBL. BOSCH |
| 14 | 1 | SCB0000549 | CILINDRO SERIE PRA D.50X125 BOSCH |
| 15 | 1 | SCB0000546 | ELEMENTO NOT G1/4 TUBO D.4 BOSCH |
| 16 | 2 | SCB0000356 | REGOLATORE DI FLUSSO UNID. 1/4" - 8 |
| 17 | 1 | S340114593A | TESTA A SNODO M16X1,5 C/DADO |
| 18 | 1 | SCB0000551 | CERNIERA POST. FEMMINA MP2 D.50 BOSCH |
| 19 | 1 | S340013592Z | ANELLO ARRESTO X ALBERO BR. |
| 20 | 1 | SBC0011031T | BUSSOLA RIDUZIONE TESTA A SNODO |
| 21 | 1 | S340365693Z | VITE TE M12X40 ZINC. |
| 22 | 1 | S340073593Z | DADO M12 AUTOBLOCCANTE |
| 23 | 1 | S3403598ZZZ | SPEZZONE CATENA 3/8" - 43 PASSI |
| 24 | 1 | S3400201ZZZ | SPEZZONE CATENA 3/8" DA 65 PASSI |
| 25 | 2 | S320103793Z | TIRANTE X CATENA SM/XL/3M |
| 26 | 1 | S330589993Z | FORCELLA DESTRORSA SM/F-104 |
| 27 | 2 | S330560393Z | FORCELLA SINISTRORSA F-104 |
| 28 | 1 | S330560493Z | BLOCCHETTO FISS. CATENA |
| 29 | 2 | S330560293Z | VITE TENDICAT. DX/SX SM4/F-104 |
| 30 | 2 | S340000293Z | DADO M6 ZINCATO |
| 31 | 3 | S330618492Z | VITE SPEC. TC M3X20 |
| 32 | 1 | S330618592Z | VITE SPEC. TC M3X25 |
| 33 | 4 | S340101493Z | DADO AUTOBLOCCANTE M3 ZINCATO |
| 34 | 2 | S330560593Z | RONDELLA /3/10X3 ZINCATA |
| 35 | 2 | S340090592Z | ANELLO DI SICUREZZA 3,2 DIN 6799 |
| 36 | 2 | S471000500A | VALVOLA BISTABILE 5/2 CON ACCESSORI |
| 37 | 1 | S3803439ZZZ | RIDUZ. INNESTABILE 3166.04.08 L633-DG |
| 38 | 1 | S3803510ZZZ | RACCORDO A T 8/8/8 |
| 39 | 1 | S3801682A | RACCORDO A Y TUBO 4 |
| 40 | 2 | SBC0011030T | DISTANZIALE ANTERIORE CHIUDIFALDE |
| 41 | 2 | S340006293Z | RONDELLA X VITE M12 ZINC. |
| 42 | 1 | S3802349ZZZ | RACCORDO DIRITTO F-1/4 TUBO 8 |
| 43 | 1 | S3802358ZZZ | RACCORDO A L-1/4 TUBO 8 |
| 44 | 1 | SCB0000552 | AVVIATORE PROGRESSIVO G1/4 |

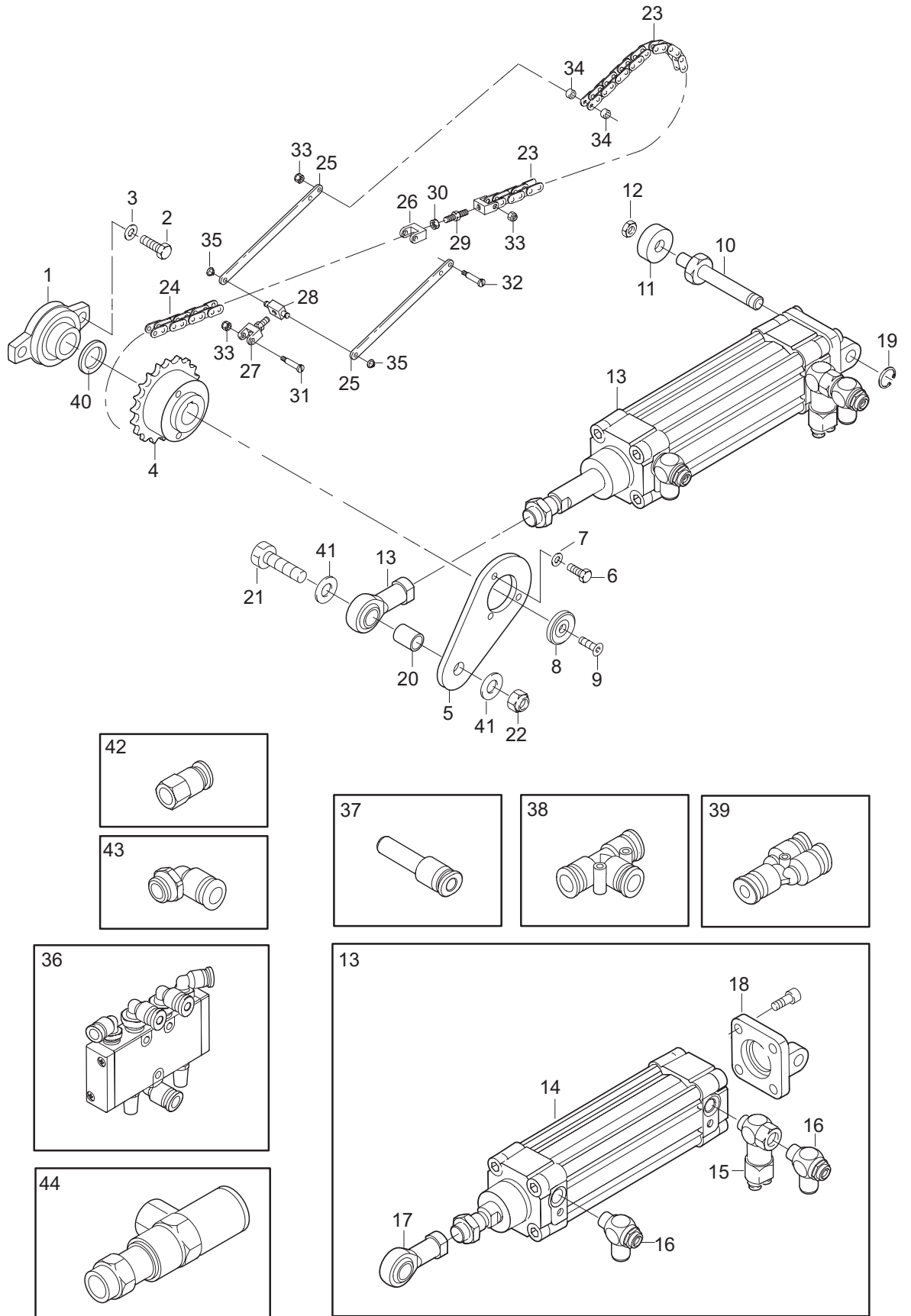

| Pos. | Q.tà | Codice | Descrizione |
|------|------|--------------|----------------------------------------|
| 1 | 1 | SBA0007027 | SUPPORTO VALVOLA C/INSERTI SX |
| 2 | 1 | SBA0007028 | SUPPORTO VALVOAL C/INSERTI DX |
| 3 | 2 | SBA0007029 | PERNO CAMMA CHIUDIFALDE C/BUSSOLE |
| 4 | 2 | S330641390Z | CERNIERA CAMMA CHIUDIF. F104 |
| 5 | 23 | S340002693Z | VITE TE M6X16 ZINCATA |
| 6 | 35 | S340017593Z | RONDELLA PIANA X VITE M6 ZINC. |
| 7 | 4 | S330540393Z | PORTA AMMORTIZZATORE K7 ZINC. |
| 8 | 4 | S310108548Z | AMMORTIZZATORE X PORTALAMA K13-K14/3m |
| 9 | 4 | S340040393Z | VITE TESVEI M5X16 ZINCATA |
| 10 | 4 | S340046893Z | RONDELLA TRIPLA X VITE M5 ZINC. |
| 11 | 4 | S340002393Z | DADO M5 ZINCATO |
| 12 | 2 | SBC0011034 | CAMMA CHIUDIFALDE |
| 13 | 2 | S4710005600A | GRUPPO VALVOLA 3/2 TESTATA (R70) |
| 14 | 4 | S3800622ZZZ | RACCORDO GOMITO GIR. 31990410 |
| 15 | 2 | S3810003600A | VALVOLA 3/2 COMANDO MECCANICO SERIE AP |
| 16 | 4 | S340014293Z | VITE TCEI M4X25 ZINCATA |
| 17 | 4 | S340000193Z | DADO M4 ZINCATO |
| 18 | 8 | S340004393Z | RONDELLA PIANA X VITE M4 ZINC. |
| 19 | 1 | SBA0006904T | GUIDASCATOLE ASS. |
| 20 | 4 | SBC0010986T | DISTANZIALE GUIDASCATOLE |
| 21 | 4 | S340025893Z | DADO AUTOBLOCCANTE M6 ZINC. |
| 22 | 1 | SBC0010990 | SCIVOLO INGRESSO SCATOLA |
| 23 | 2 | S340005493Z | VITE TSVEI M4X10 ZINCATA |
| 24 | 2 | SBC0011002T | PERNO CHIUDIFALDA |
| 25 | 2 | S3400238ZZZ | LINGUETTA 6X6X20 |
| 26 | 2 | S3100711ZZZ | SUPPORTO DX BRACCIO CHIUD. F104 |
| 27 | 2 | S330640793Z | RONDELLA /14X30X5 F104 ZINC. |
| 28 | 2 | SBC001007 | PIASTRA CHIUDIFALDA |
| 29 | 12 | S340040793Z | VITE TE M6X10 ZINCATA |

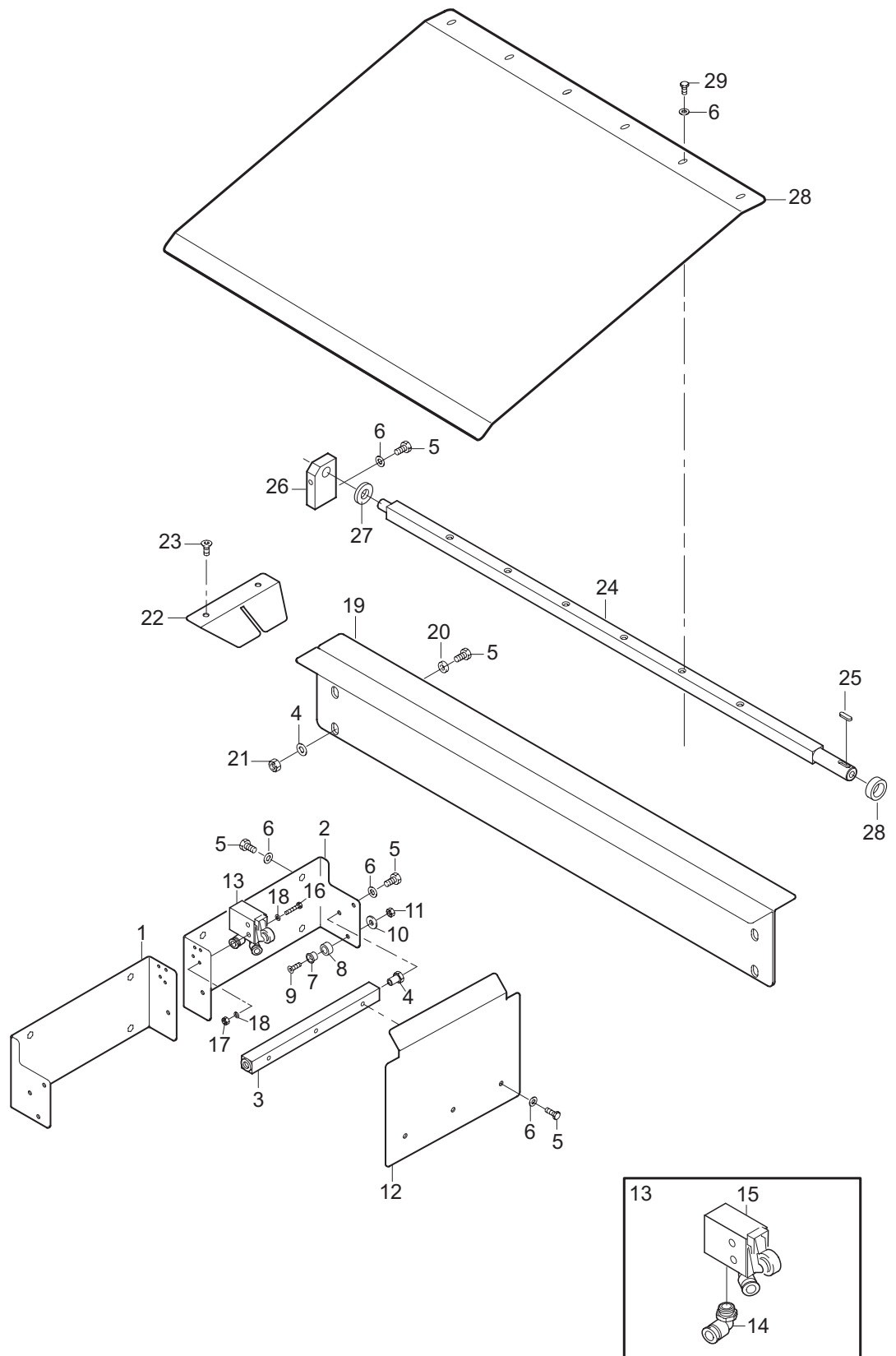

Fig. 15240 COMPONENTI ELETTRICI SEB0000488 STAZIONE DI CONFEZIONAMENTO

| Pos. | Q.tà | Codice | Descrizione |
|-------------|-------------|---------------|------------------------------------------|
| 1 | 1 | SBB0001956 | Q. E. 380/415 V 50/60 HZ 3PH+PE |
| 2 | 1 | S3803662ZZZ | BOBINA DI MINIMA 220V 140A-C-UXA |
| 3 | 1 | SCC0001290 | MORSETTO DOPPIO DI TERRA UTTB 2,5-PE |
| 4 | 5 | S380594800A | DADO PER BOCCHETTONE M20X1,5 GRIGIO |
| 5 | 5 | S380582600A | BOCCHETTONE PRESSACAVO M20X1,5 GRIGIO |
| 6 | 1 | S3805072ZZZ | INT. MAGNETOTERMICO 4-6.3 A 140A-C2A-B63 |
| 6 | 1 | S3801830ZZZ | INTERR. TERMICO 1-1.6 A 140A-C2A-B16 |
| 6 | 1 | S3801844ZZZ | INTERR. TERMICO 1,6-2,5 A 140A-C2A-B25 |
| 7 | 1 | SBA0006858 | CASSETTA INTERR. C/INSERTI |
| 8 | 1 | SBC0010907V | COPERCHIO CASSETTA |
| 9 | 1 | SCC0001616 | FRONTALINO IP55 140A-C-N18 |
| 10 | m | SCC0000396 | CAVO 4X1,5 |
| 11 | m | S3801222ZZZ | CAVO 3X1,5 |
| 12 | m | SCC0000613 | CAVO 3G 0,75 |
| 13 | 1 | SCC0001615 | CONTATTO AUSILIARIO 140A-C-AEA10 |

